

Single-Molecule Spectroscopy, Imaging, and Photocontrol: Foundations for Super-Resolution Microscopy

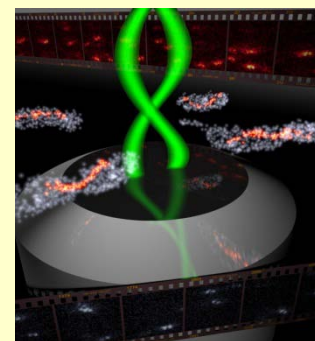
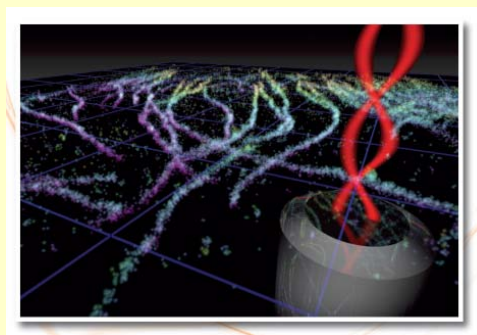
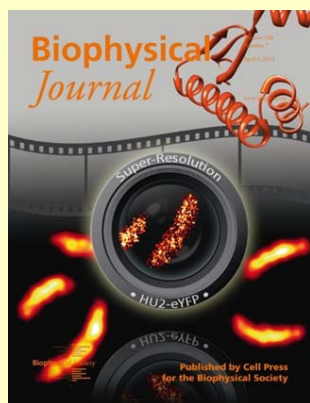
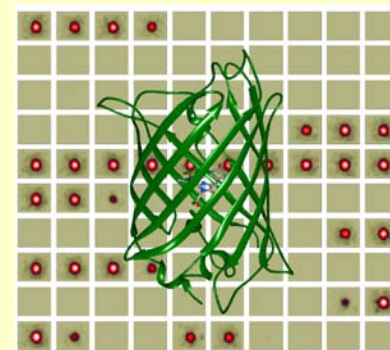
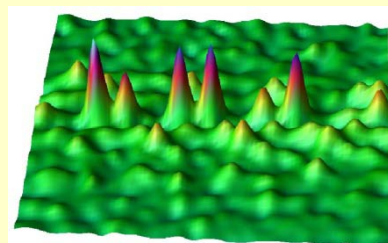
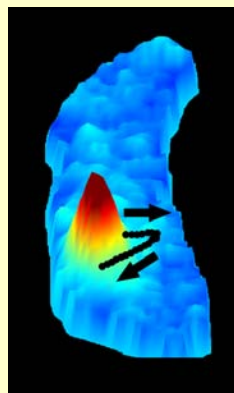
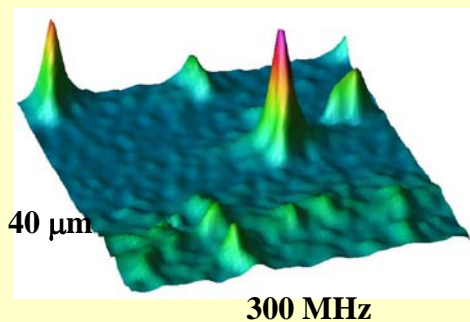

W. E. Moerner

Harry S. Mosher Professor of Chemistry and Professor, by courtesy, of Applied Physics
BioX, Biophysics, MIPS, and ChEM-H Programs, Stanford University

Nobel Prize in Chemistry Lecture
Stockholm, Sweden, 8 December 2014



Erwin R. J. A. Schrödinger

“...we *never* experiment with just *one* electron or atom or (small) molecule. In thought-experiments we sometimes assume that we do; this invariably entails ridiculous consequences...In the first place it is fair to state that we are not *experimenting* with single particles, any more than we can raise Ichthyosauria in the zoo.

“Are There Quantum Jumps? Pt. II” *British J. for the Philosophy of Science* **3**, 233-242 (1952).

Spectrum (absorption vs. wavelength, or color) at room T

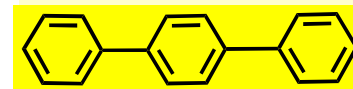
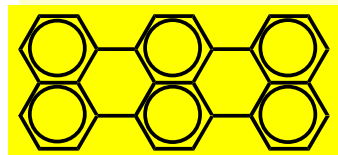
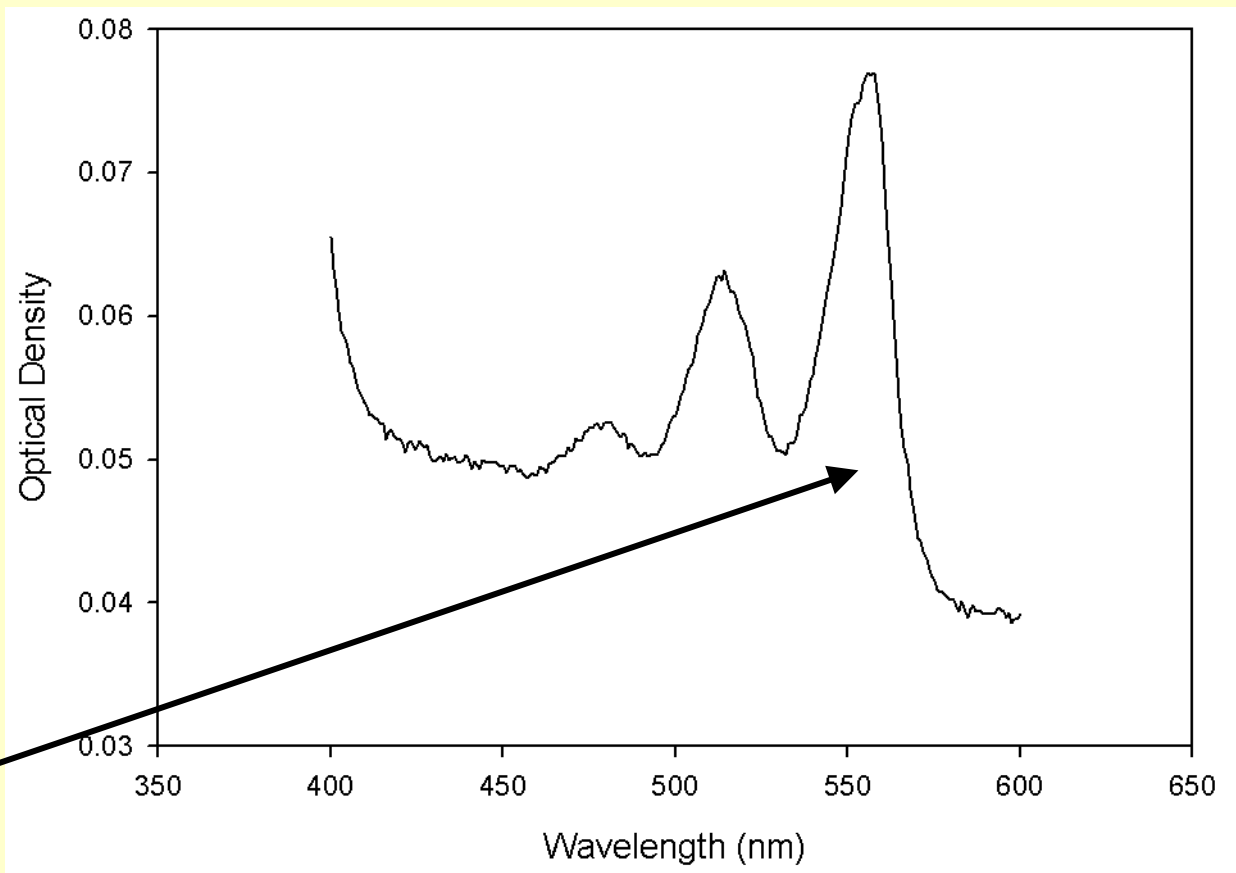

Terrylene in
p-Terphenyl

Now lets
expand the
color scale by
25x here, and
cool to low T

860 THz

460 THz=460x10¹² cps

Frequency=(c/wavelength)

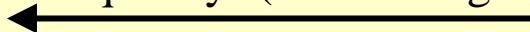

Optical Spectroscopy of Molecules in Solids



Spectrum (absorption vs. frequency, or color) at low T (2K)

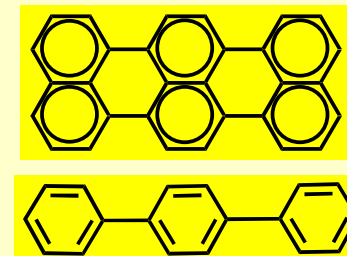
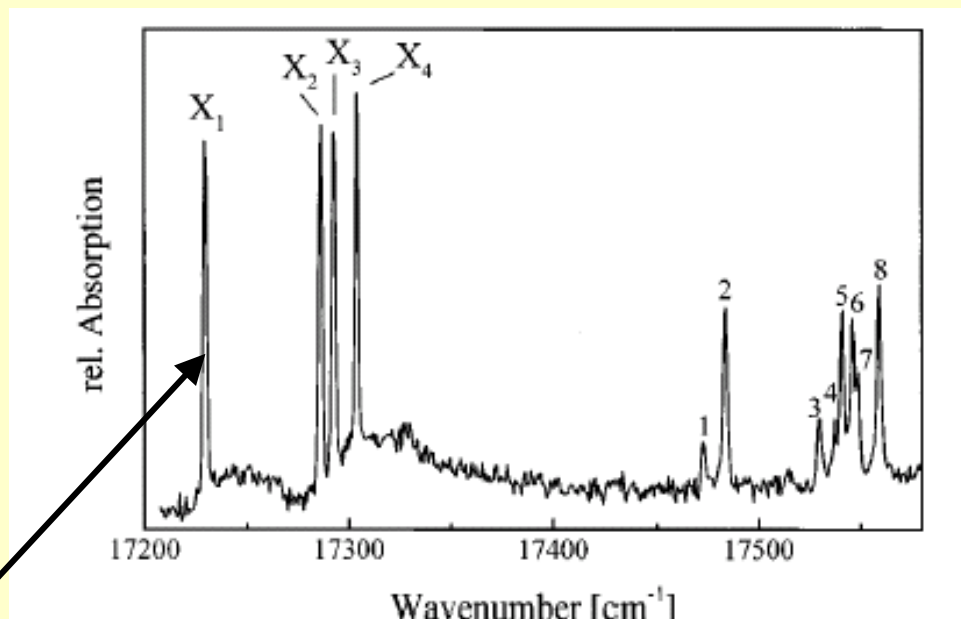

Terrylene in
p-Terphenyl

Now blow up
the scale here
by another
1000X !

581 nm
516 THz

569 nm
527 THz

→
Frequency=(c/wavelength)

Early Steps Toward Single-Molecule Spectroscopy

Crucial concepts circa 1985 at IBM Research:

- Zero-phonon, purely electronic transitions of fairly flat, rigid molecules in solids at low T become **extremely narrow**
- An inhomogeneous line profile occurs due to tiny variations in local environments
- To get homogeneous widths: need photon echoes, ... or
- Spectral hole-burning: laser-induced changes make a dip or “hole” at chosen laser colors

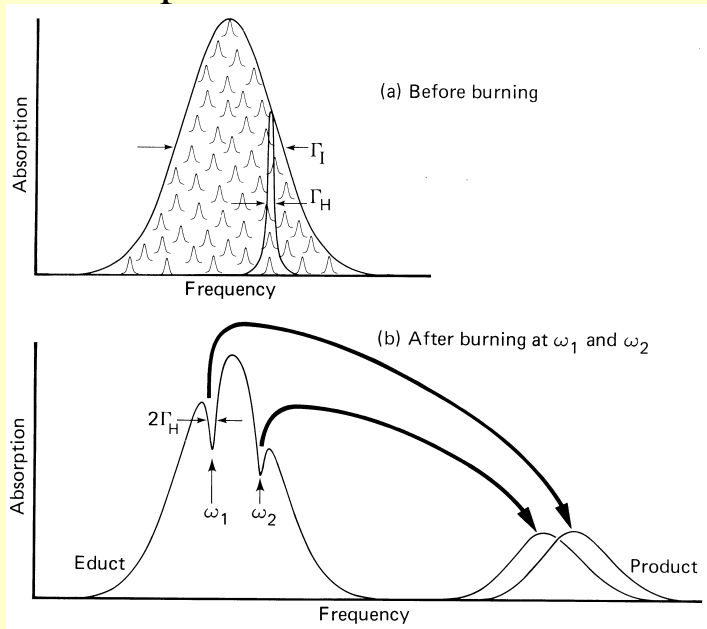
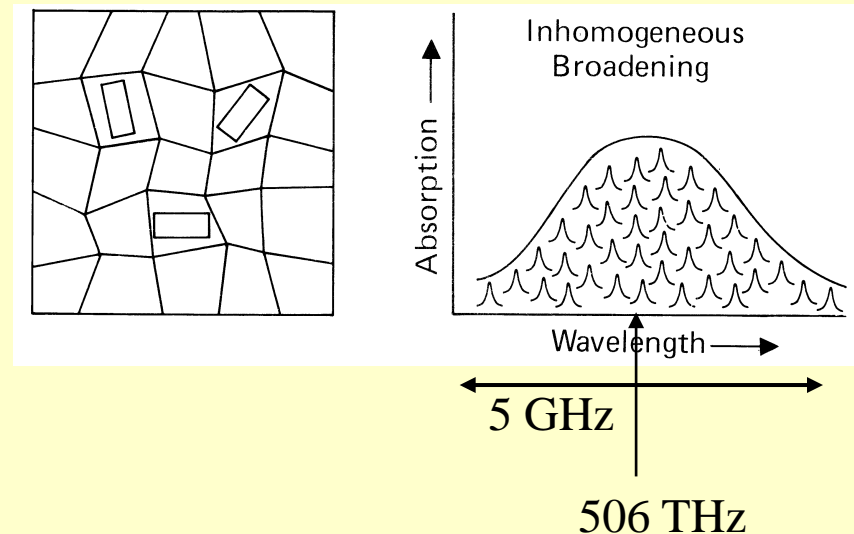

What are the ultimate limits to “frequency domain” optical storage by spectral hole-burning?

Fundamental Question: Is there a “spectral noise” that results from statistical number fluctuations or the discreteness of individual molecules? – this would define the smallest possible spectral hole that can be detected.

Suppose you have 10 boxes, and throw 50 balls at these boxes with all boxes being equally likely.

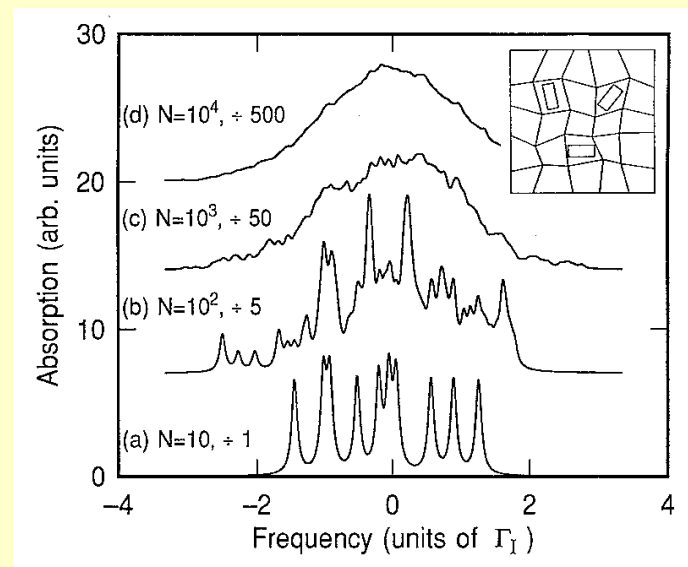
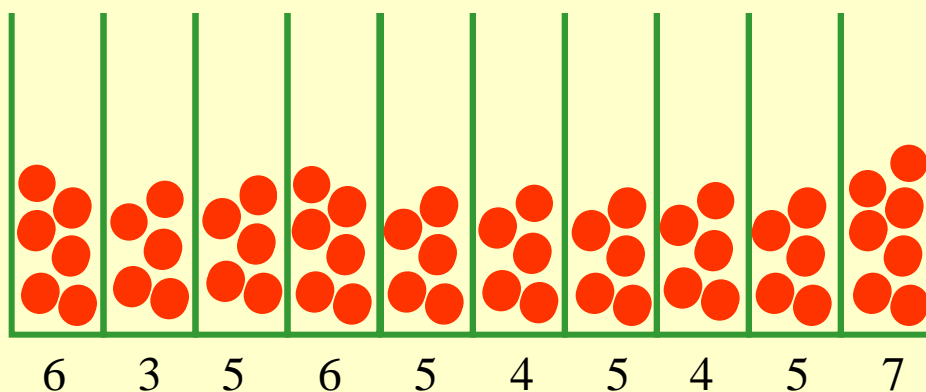

This is the well-known number fluctuation effect, scaling as \sqrt{N} , that arises from sampling.

Key Idea: Now think of the horizontal axis as optical frequency (or wavelength).

Each box is a bin of width $\Delta\nu$, the homogeneous width of an optical absorption line.

Then the resulting spectrum should have a spectral roughness or fine structure scaling as \sqrt{N} , which arises from the discreteness of the individual molecules!

Statistical Fine Structure in an Inhomogeneously Broadened Line

WEM and T. P. Carter, *Phys. Rev. Lett.* **59**, 2705 (1987)

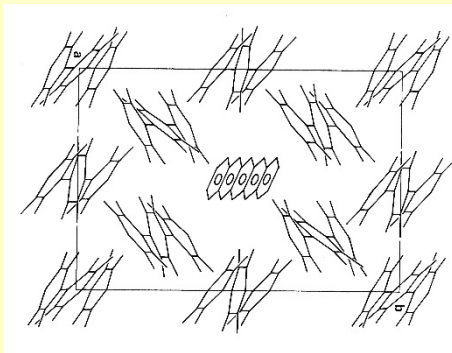

pentacene in
p-terphenyl
crystal, 1.4K

- Number of molecules per $\Delta\nu_H$: N
- Fluctuations in N should scale as \sqrt{N}
- Call this Statistical Fine Structure (SFS)
- Detection achieved with FM spectroscopy since it measures $\Delta\alpha$ on the 100 MHz scale, or $\alpha(\text{upper}) - \alpha(\text{lower})$

SFS arises directly from the discreteness of the individual molecules.

The single-molecule limit is within reach!

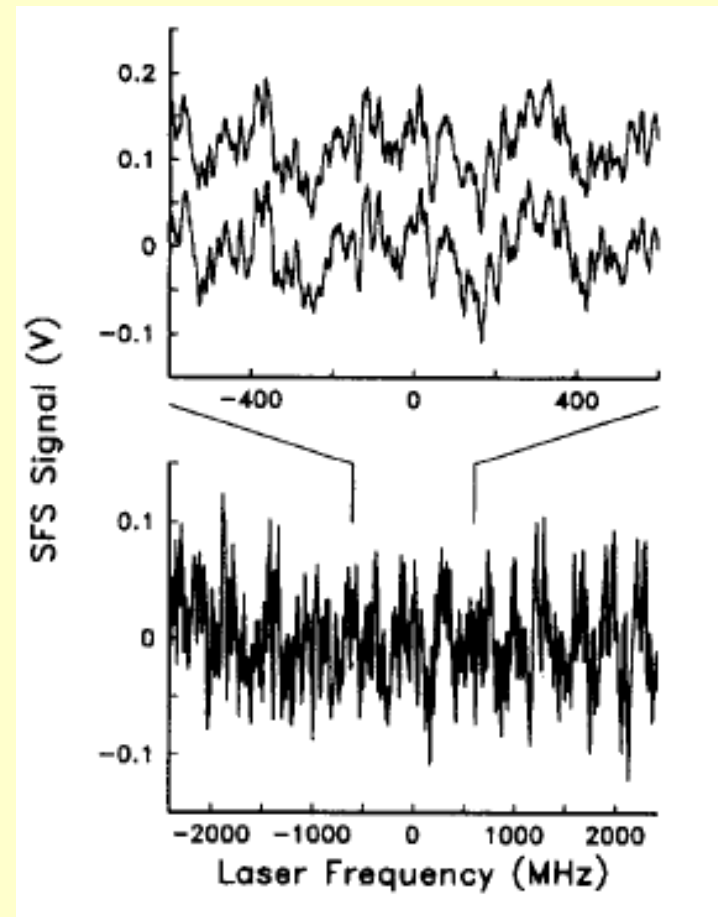

T. P. Carter and WEM, *J. Chem. Phys.* **89**, 1768 (1988)

Detecting Single-Molecule Absorption



VOLUME 62, NUMBER 21

PHYSICAL REVIEW LETTERS

22 MAY 1989

Optical Detection and Spectroscopy of Single Molecules in a Solid

W. E. Moerner and L. Kador^(a)

IBM Research Division, Almaden Research Center, San Jose, California 95120

(Received 17 March 1989)

PRL 62, 2535 (May 1989)



- Pentacene in crystalline *p*-terphenyl, 1.8 K, 593 nm
- Laser FM absorption spectroscopy with Stark (E-field) or ultrasonic (strain field) secondary modulation
- Insensitive to scattering from sample
- Limited by laser shot noise (and out-of-focus molecules from relatively thick cleaved crystal)
- Challenge: focused laser intensity had to be kept low
- Proof-of-principle: single molecules can be optically detected; pentacene/*p*-terphenyl is a useful model system

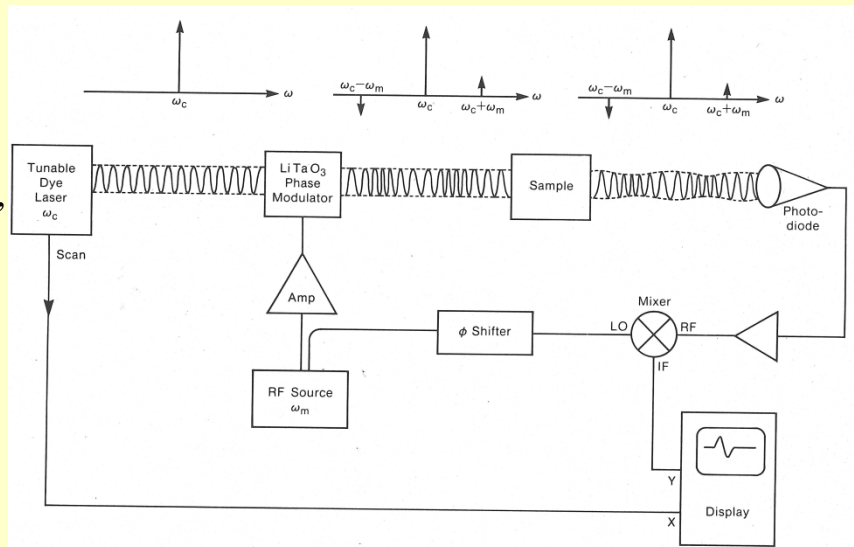
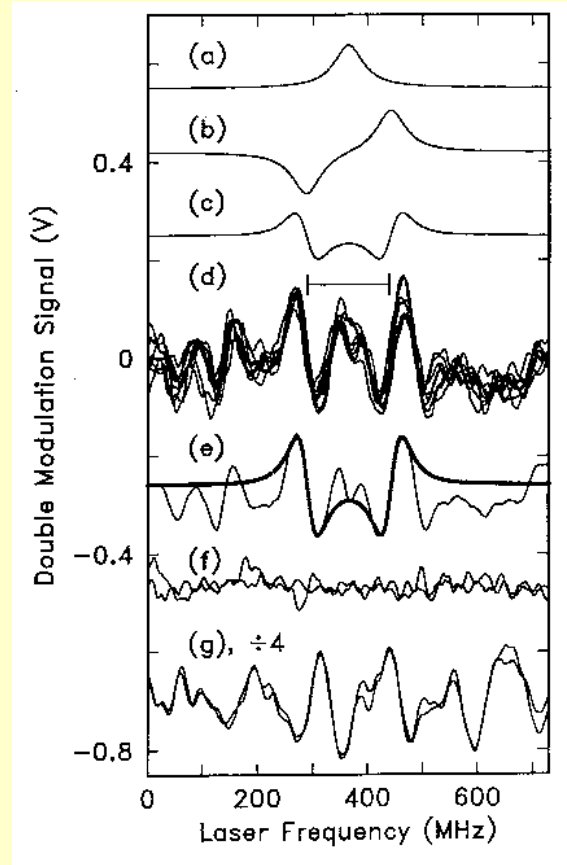

FM: G. Bjorklund, *Opt. Lett.* **5**, 15 (1980)



Like FM Radio at 506 THz!

Detecting Single-Molecule Absorption from Emitted Fluorescence

VOLUME 65, NUMBER 21

PHYSICAL REVIEW LETTERS

19 NOVEMBER 1990

Single Pentacene Molecules Detected by Fluorescence Excitation in a *p*-Terphenyl Crystal

M. Orrit and J. Bernard

Centre de Physique Moléculaire Optique et Hertzienne, Centre National de la Recherche Scientifique et Université de Bordeaux I,
351, Cours de la Libération, F-33405 Talence CEDEX, France

(Received 9 July 1990)

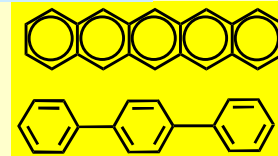

- Used the pentacene/*p*-terphenyl model system
- Detected absorption by measuring emitted fluorescence
- Sensitive to scattering from sample, so careful sample growth required – crystal clear sublimed flakes
- Limited by Rayleigh and Raman scattering background signals, but produced higher SNR for equal bandwidth

PRL **65**, 2716 (November 1990)

An application of Laser-Induced Fluorescence
(LIF in molecular gas - R.N. Zare, 1968)

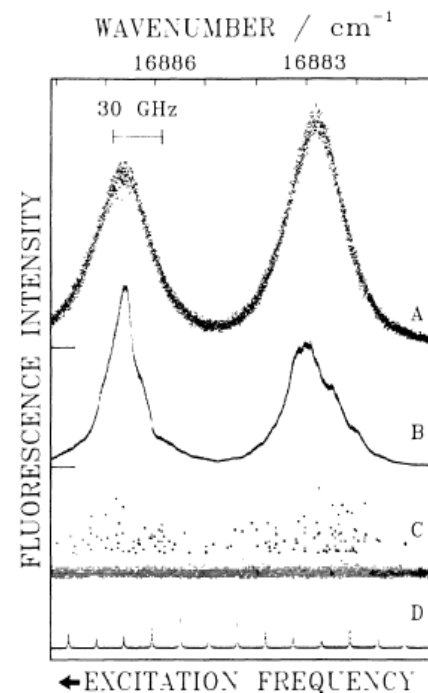
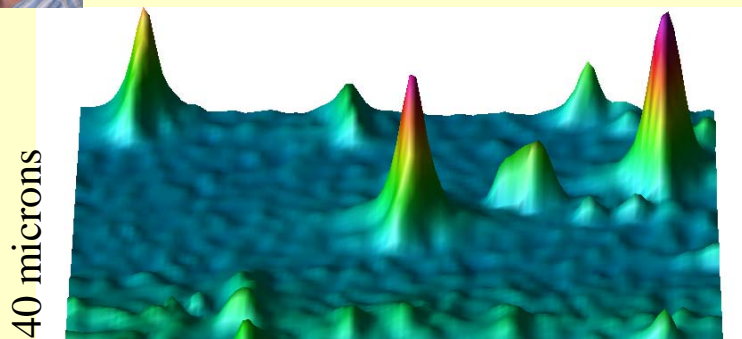

FIG. 1. O_1, O_2 region of the fluorescence excitation spectra of pentacene in different *p*-terphenyl crystals. Curve *A*, thick melt-grown crystal showing the Gaussian inhomogeneous bands. *B*, sublimation flake presenting narrower bands and substructure presumably due to cooling-induced defects. *C*, spectrum of a very small volume of a sublimation flake. The dots are the narrow excitation peaks of individual molecules. *D*, calibration spectrum of an etalon.

Single-Molecule Imaging and Spectroscopy



W. P. Ambrose, WEM, Nature **349**, 225 (1991)



40 microns

The width of

the peaks along the position axis (FWHM = 5 μm) is a direct measure of the intensity profile of the focused laser beam in the crystal.

Spatial scan: SM measures laser spot size with nm probe!

Freq. scan: Second dimension selects one molecule from many in the same focal volume

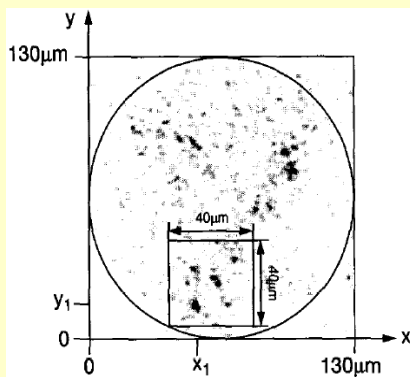

Widefield
2D
Microscopy

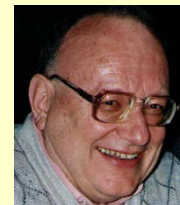

Güttler,... Wild, ChemPhysLett **217**, 393 (1994)

0 GHz \equiv 592 nm \equiv 506 THz

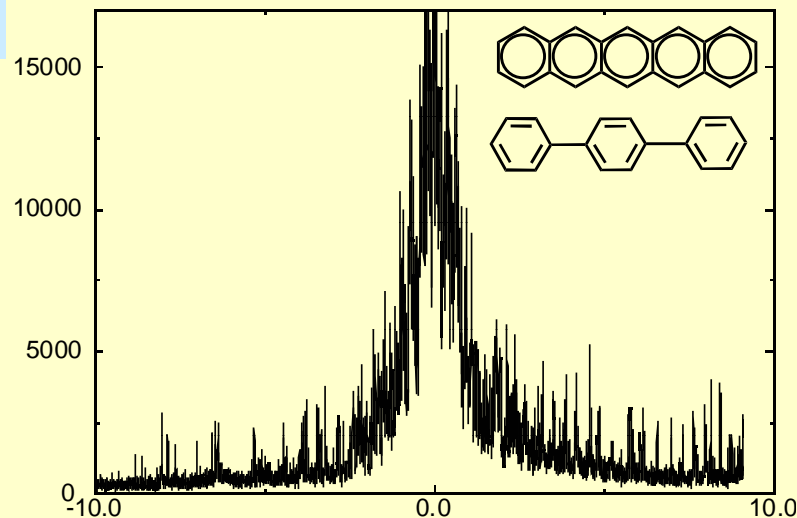

Fluorescence (cps)

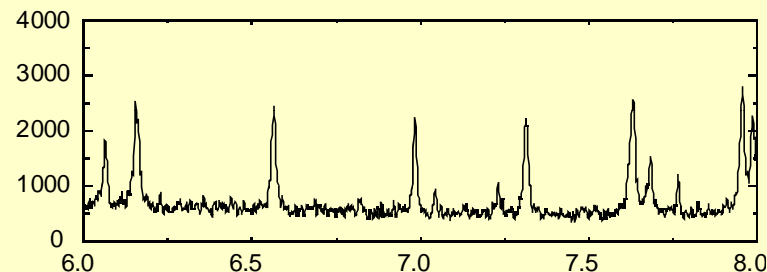

GHz

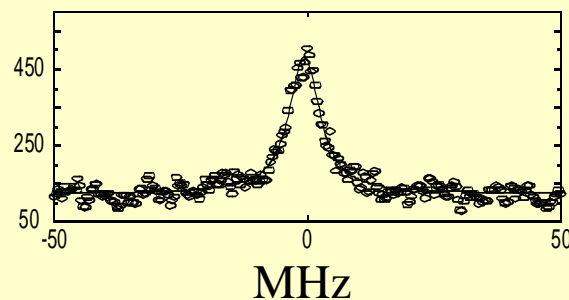

Ultralow intensity:
(1.8 mW/cm²)
Lifetime-limited
width:
7.6 MHz Wow!

MHz

Some of the Surprises from Single Molecules!



Fluorescence excitation spectrum during repetitive scanning of cw dye laser over 400 MHz at 506 THz:

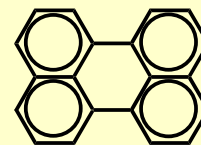
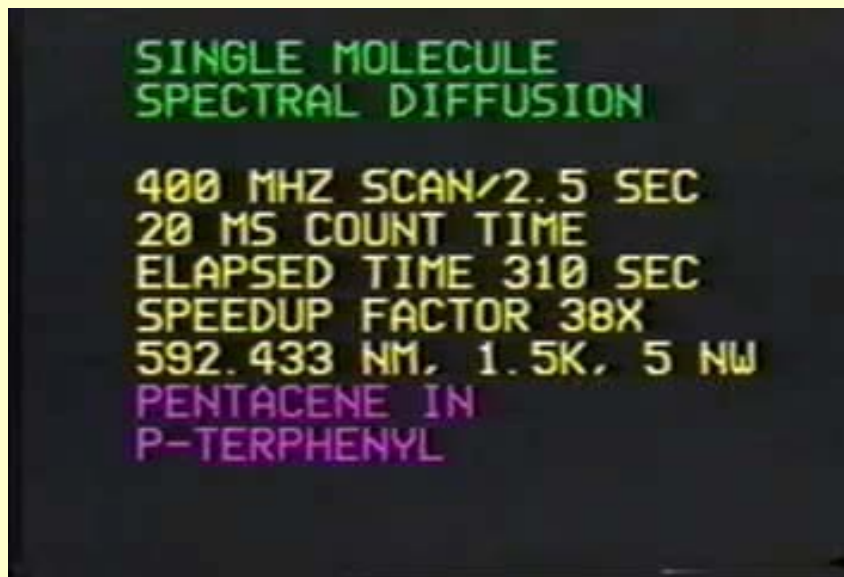

in
(CH₂-CH₂)_n



Optically induced spectral shifts!
Poisson kinetics observed

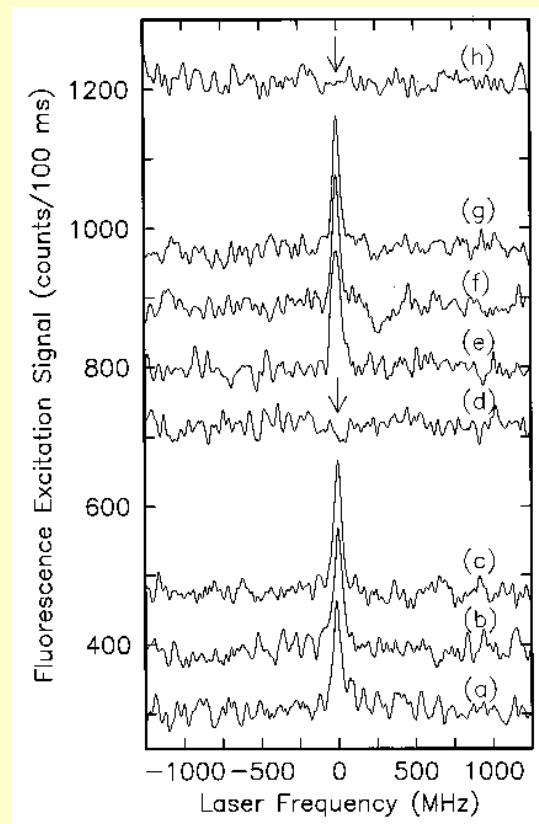

Molecule spontaneously jumps in frequency space due to nearby host dynamics!

W. P. Ambrose, WEM, Nature **349**, 225 (1991)
Theory: P. Reilly, J. Skinner, PRL **71**, 4257 (1993)
T-dep: A. Zumbusch, M. Orrit, PRL **70**, 3584 (1993)

Th. Basché and WEM, Nature **355**, 335 (1992)

Motivations and Impact: Single-Molecule Spectroscopy and Optical Imaging in Complex Systems



Remove Ensemble Averaging

- **Explore heterogeneity:** are the various copies identical in behavior, or are they different?
- **Follow state changes in time,** especially in biological processes and complex materials
- Test theoretical understanding of stochastic behavior

Image/Detect nm-Scale Interactions

- Single molecule as a nm-sized reporter and nanometer-sized light source
- Distance rulers by FRET, TJ Ha et al. (1996)
- Probe local fields in nanophotonic structures
- **Super-resolution imaging**

Commercial: Sequence DNA, Imaging

- PacBio sequencing with ZMW's, ...
- ...single-photon sources, ...
- Super-resolution Microscopes

Room Temperature: Milestones of Single-Molecule Detection and Imaging

Solution: Correlation functions	Fluorescence Correlation Spectroscopy: Magde, Elson, Webb (1972, 1974); Ehrenberg, Rigler (1974); Pecora (1976); ...
	Autocorrelation (FCS) from 1 fluorophore or less in the volume: Rigler, Widengren, BioScience (1990)
Solution: Single bursts	Multichromophore emitter bursts (phycoerythrin): Peck, Stryer, Glaser Mathies PNAS 86 , 4087 (1989)
	Single bursts from 1 fluorophore : Shera, Seitzinger, Davis, Keller, Soper, Chem.Phys.Lett. 174 , 553 (1990); Nie, Zare, Science (1994);...
Solution and surface	Single antibody with multiple (~80-100) labels: T. Hirschfeld, Appl. Opt. 15 , 2695 (1976)
Near-Field NSOM, SNOM	Imaging a single fluorophore : Betzig and Chicester, Science 262 , 1422 (1993); Ambrose,..., Keller PRL 72 , 160 (1994); Xie and Dunn, Science 265 , 361 (1994)
Confocal image	Macklin, Trautman, Harris, Brus, Science 272 , 255 (1996); ...
Widefield, single fluorophore	<i>In vitro</i> , myosin on actin: Funatsu,...Yanagida, Nature 374 , 555 (1995).
	Cell membrane, single-lipid tracking with super-localization, Schmidt, Schütz, ...Schindler, PNAS 93 , 2926 (1996).

Detecting Single-Molecule Absorption from Emitted Fluorescence at Room T

- Typical organic fluorophore labels are only ~ 1 nm in size, fluorescent proteins ~ 3 -4 nm
- Light pumps electronic transitions of the molecule
- Signal indirectly reports on local nanoenvironment because only one molecule is pumped and measured, if backgrounds are low and molecule emits light efficiently

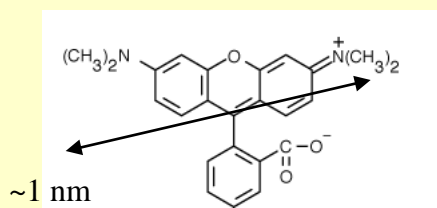
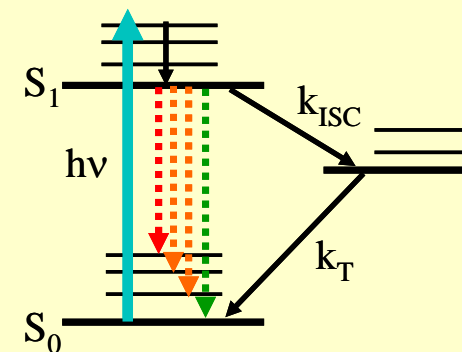

TMR

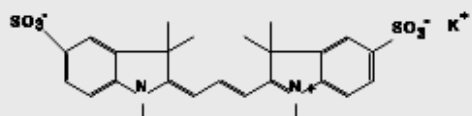

Cy3

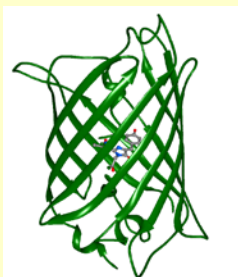
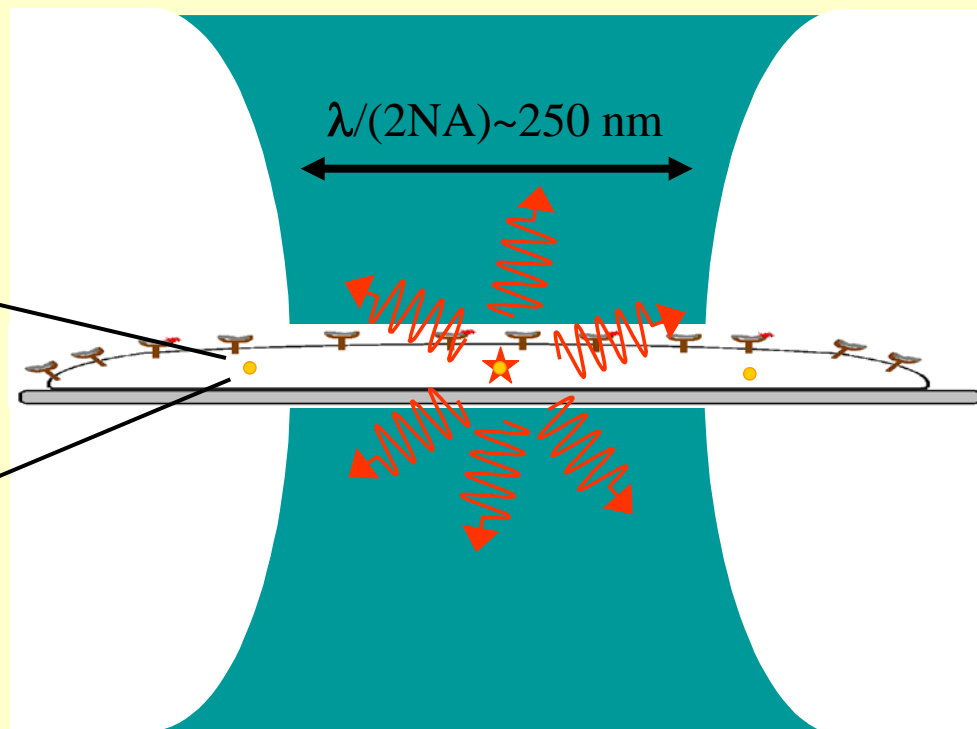
GFP, FPs
(~ 3 nm x 4 nm)

Single-Molecule Imaging and Tracking Examples – Much to Learn from Isolated Single Molecules!



Immune proteins in membrane of a live CHO cell

Vrljic, Nishimura, McConnell, WEM, Biophys. J. (2002)

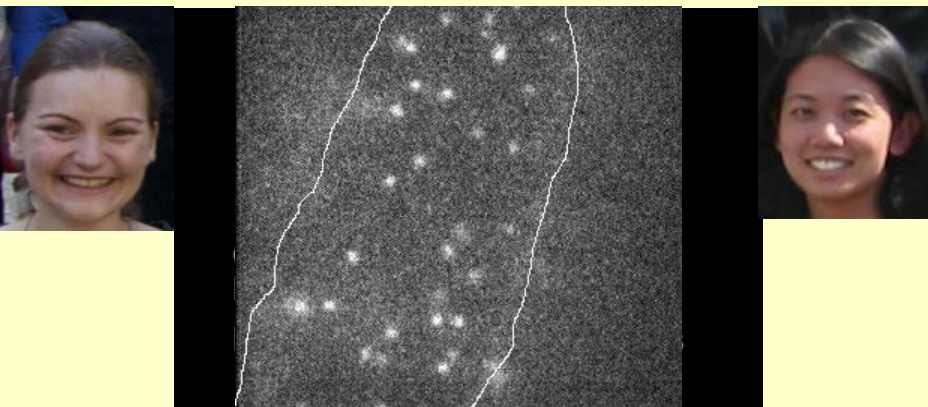

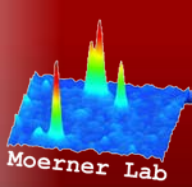

Super-Resolution Microscopy with Single Molecules



How can we use single-molecule labels to surpass Abbé's optical diffraction limit, a fundamental physical effect in the far-field?

Single-molecule imaging + 2 key ideas

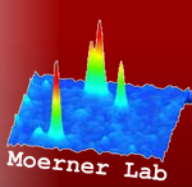

Key Idea #1: Super-Localization

cinder cone, bar 120×10^9 nm



Find the position of the emitter by fitting the shape of the single-molecule image

can easily find peak position to much better precision than the width

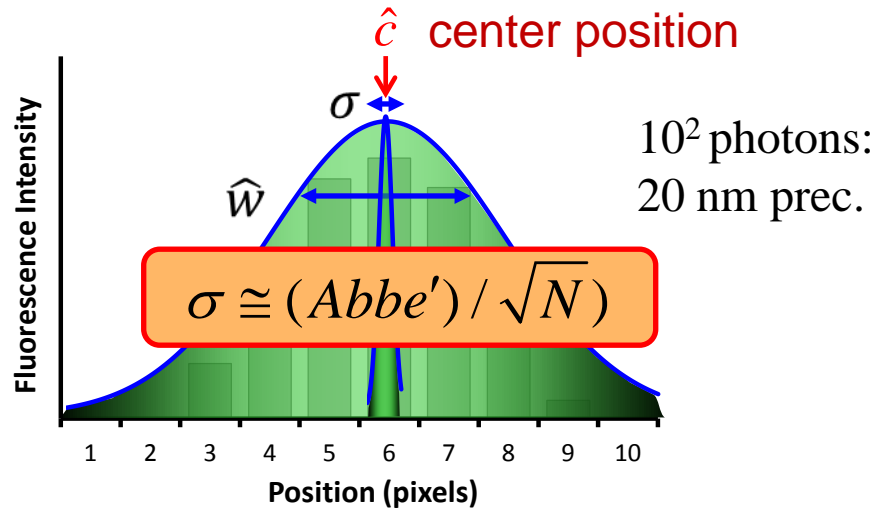
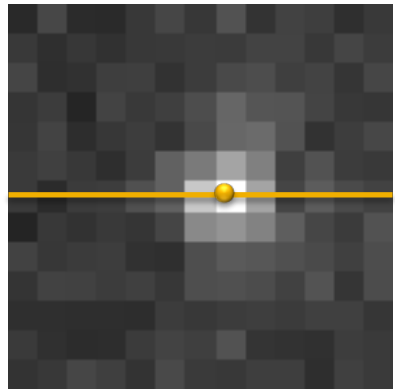
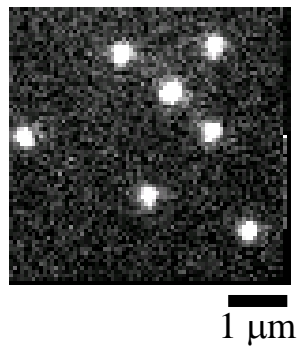

Summary: WEM, J. Microscopy **246**, 213-220 (2012)

Some Early Examples of Super-Localization in Biological Imaging



Find centroid of large fluorescent object	LDL (Low-Density Lipoprotein particles with many labels) on cell surface: Barak, Webb, J. Cell Biol 95, 846 (1982)
	Tracking kinesin motor-driven 190 nm bead with few nanometer precision: Gelles, Schnapp, Sheetz, Nature 331 , 450 (1988)
Find position of single fluorophore	Cell membrane, <u>single-lipid tracking to 30 nm precision</u> : Schmidt, Schütz, ...Schindler, PNAS 93 , 2926 (1996).
	Single virus particle on HeLa Cell to 40 nm precision: Seisenberger, ...Bräuchle, Science 294 , 1929 (2001); ...

If all photons come from the same nm-sized object, we can truly extract nanometer-scale position information, and follow the trajectory in time!

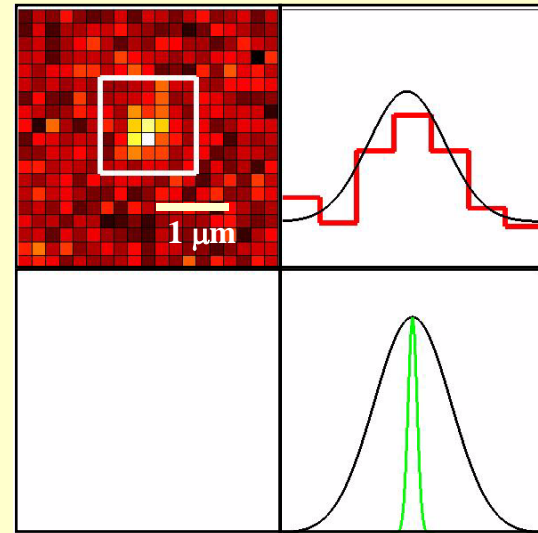

Toward Super-Resolution with Single-Molecule Emitters

Key proposal	<p>Use some additional control variable to separate DL spots in spatial dimension – spectral tunability suggested: E. Betzig, Opt. Lett. 20, 237 (1995)</p>
Low T	<p>Spectral tunability used to achieve 3D super-resolution: A. van Oijen, J. Koehler, J. Schmidt, Mueller, Brakenhoff, Chem. Phys. Lett. 292, 183 (1998) – 40 nm lateral, 100 nm axial for several single molecules</p>
Room T	<p>Distinguish two dyes by fluorescence lifetime: Heilemann,...,Sauer, Anal. Chem. 74, 3511 (2002).</p>
	<p>Use photobleaching of overlapping fluors: SHRImP: Gordon, Ha, Selvin, PNAS 101, 6462 (2004); NALMS: Qu, Wu, Mets, Scherer, PNAS 101, 11298 (2004)</p>
	<p>Two differently colored probes: SHREC: Churchman,...,Spudich, PNAS 102, 1419 (2005)</p>
	<p>Blinking of semiconductor quantum dots: Lidke, Rieger, Jovin, Heintzmann, Opt. Exp. 13, 7052 (2005)</p>

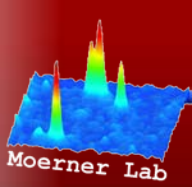

Key idea #2: Active control of emitter concentration, sequential imaging



No active control

Active control of concentration

Structural detail beyond DL revealed by sampling

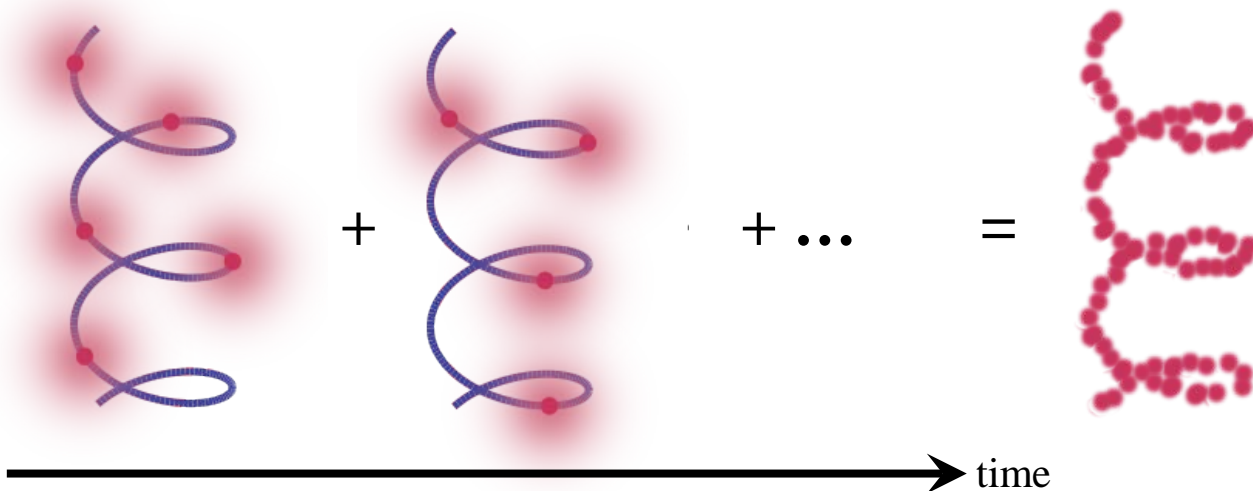

PALM (4/2006)

E. Betzig/H. Hess

STORM

X. Zhuang

F-PALM

S. Hess

(also: PAINT (Hochstrasser), dSTORM (Sauer), YFP reactivation, GSDIM (Hell), BLINK (Tinnefeld), SPDM (Cremer)...)

Mechanism-Independent: Single-Molecule Active Control Microscopy: "SMACM"

1997: Imaging, Blinking, and Photorecovery for Single EYFP (Enhanced Yellow Fluorescent Protein, a GFP variant)



R. M. Dickson, A. B. Cubitt, R. Y. Tsien, and W. E. Moerner, Nature 388, 355 (1997), U. S. Patent 6,046,925.

Imaging of single S65G/S72A/T203Y variants in a gel showed blinking and switching, i.e., thermal AND light-induced recovery from a metastable dark state

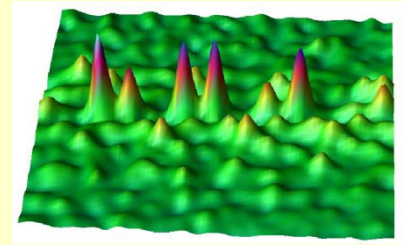

Blinking (488 nm, 100 ms)

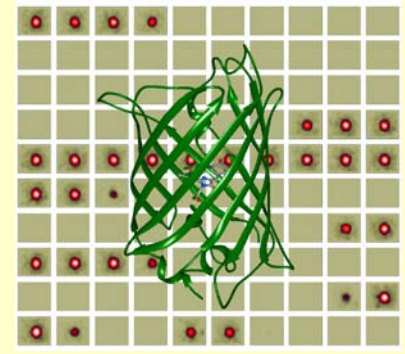

Switching: 405 nm causes recovery of yellow emission for one single molecule

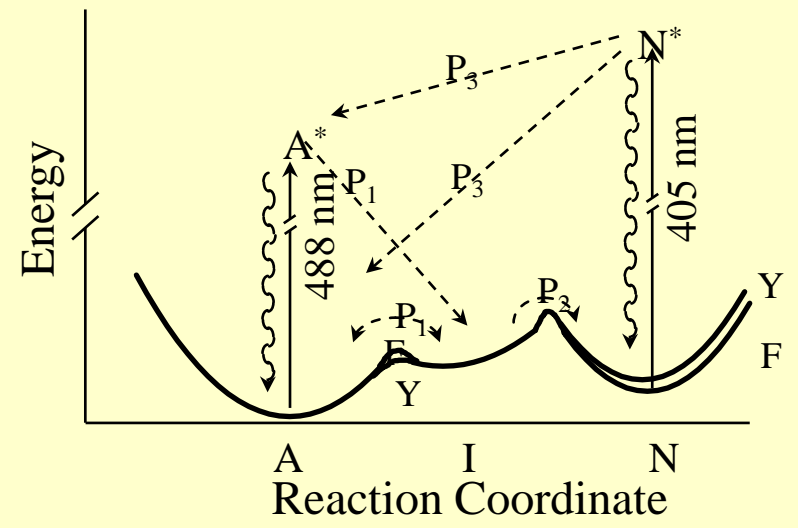
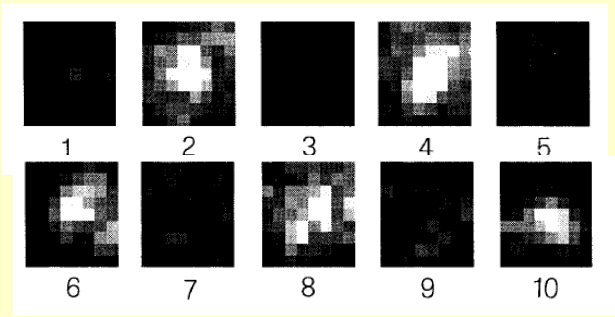

Further development of switchable FPs:
 PA-GFP: Patterson, Lippincott-Schwartz (2002)
 DRONPA: Ando, Miyawaki (2004)

...

EYFP immobilized in polyacrylamide gels

Likely photoinduced *E,Z*-isomerization of the GFP chromophore

What the data look like....

eYFP fusions to a bacterial protein blinking in
Caulobacter crescentus cells

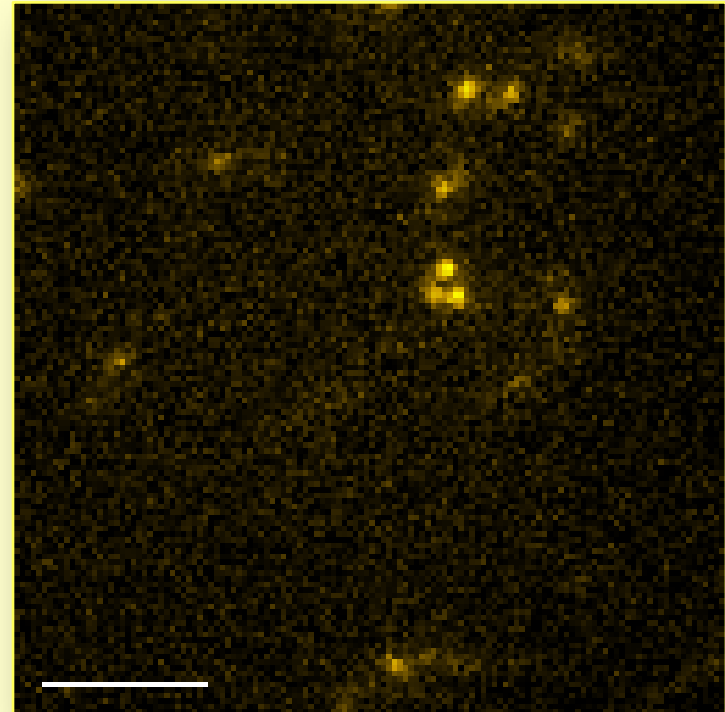

5 μ m Scale bar, 10ms per frame, movie slowed down 3X

eYFP blinking and photocontrol:

R. M. Dickson, A. B. Cubitt, R. Y. Tsien, and W. E. Moerner, Nature 388, 355 (1997).

Examples: Diffraction-Limited Imaging vs. SR

(Collaboration with Lucy Shapiro lab, Stanford)

Epi-fluorescence images, of 3 different eYFP fusions in *Caulobacter crescentus*

MreB

ParA

HU

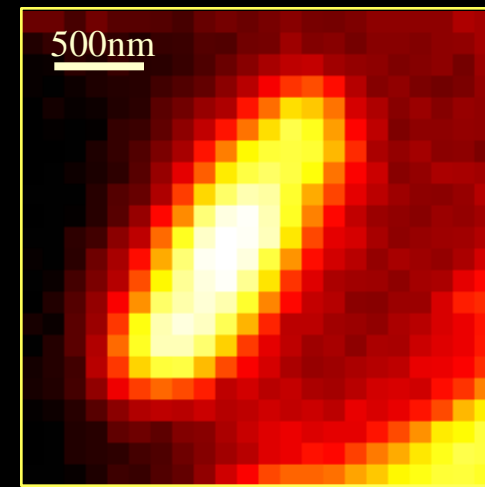
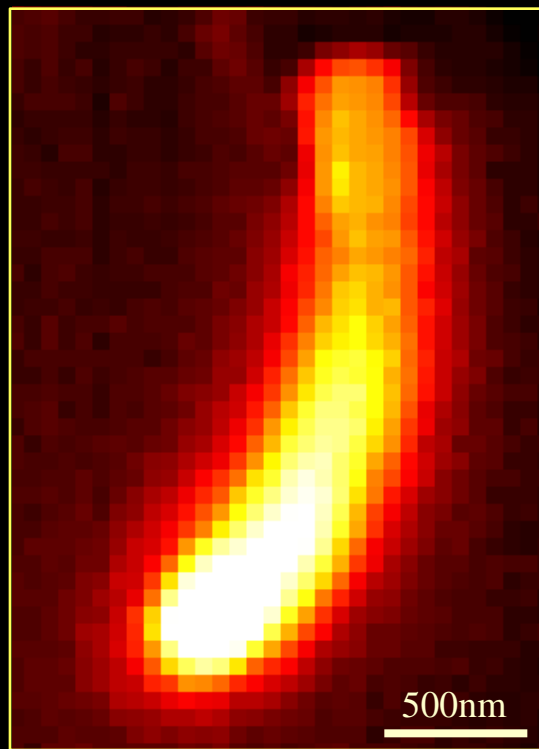
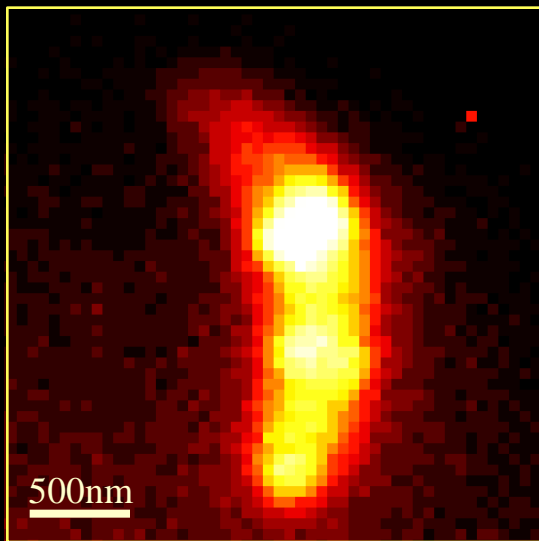

J. S. Biteen, et al. Nature Methods (2008)



Lee, Thompson, et al. BPJ Lett 2011



Ptacin, Lee, et al. Nature Cell Biol. (2010)

Super-Resolution (40 nm loc. precision) reveals multiple localization patterns!

Neuritic Spine-Like Structures: Na_v Channels in a Differentiated PC12 Cell

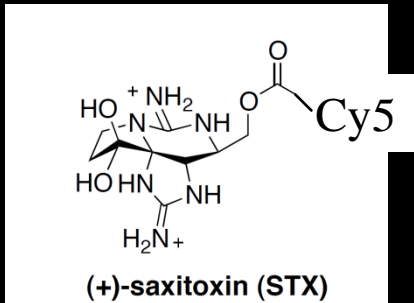

2 μm

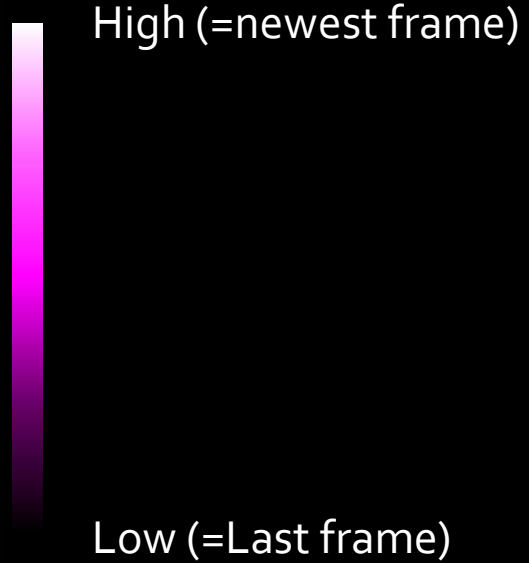

**Super-Resolution
Reconstruction, 500
ms sliding window**

(H. Lee, S. Iwanaga, ... J. DuBois, WEM, Chem.Bio.(2012))



New Fluorophores, New 3D Imaging Methods



Marissa Lee, P. Rai, J. Williams, R. J. Twieg, WEM

J. Am. Chem. Soc. **136**, 14003-14006 (2014)

Optimized rhodamine spirolactams photoswitch with blue light

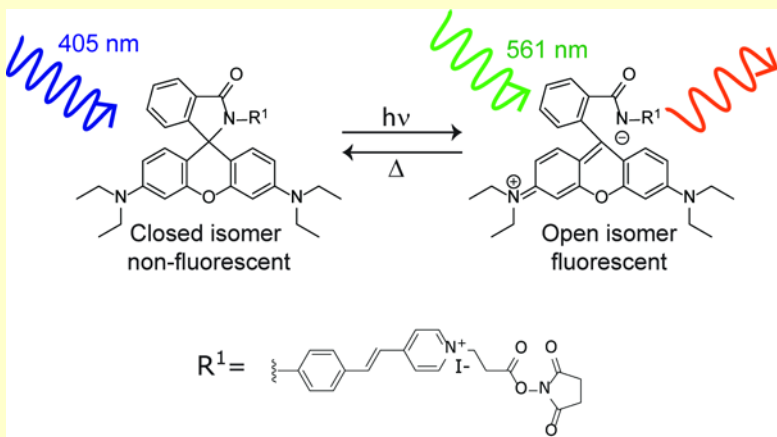

Labeling free amines on live bacteria surfaces highlights sub-diffraction-sized stalks

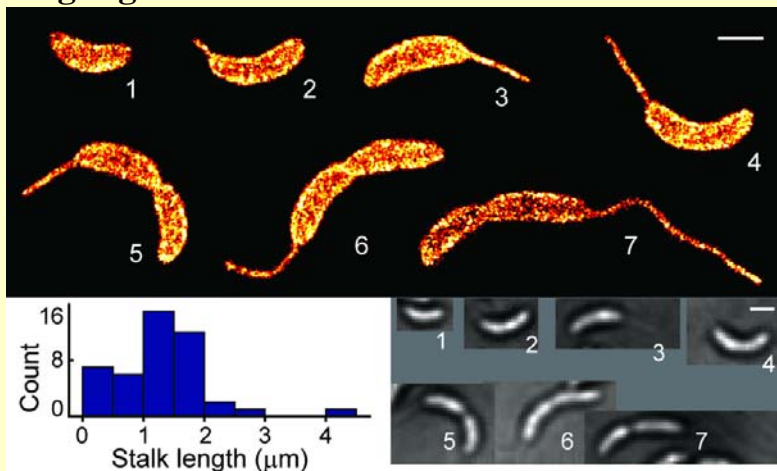

Standard Double-Helix (DH)

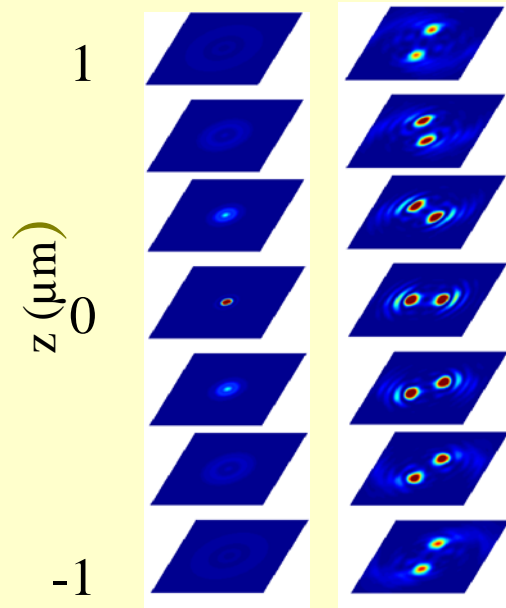

Object depth is encoded into PSF rotation for the DH-PSF

Collaboration: R. Piestun, Univ. Colorado

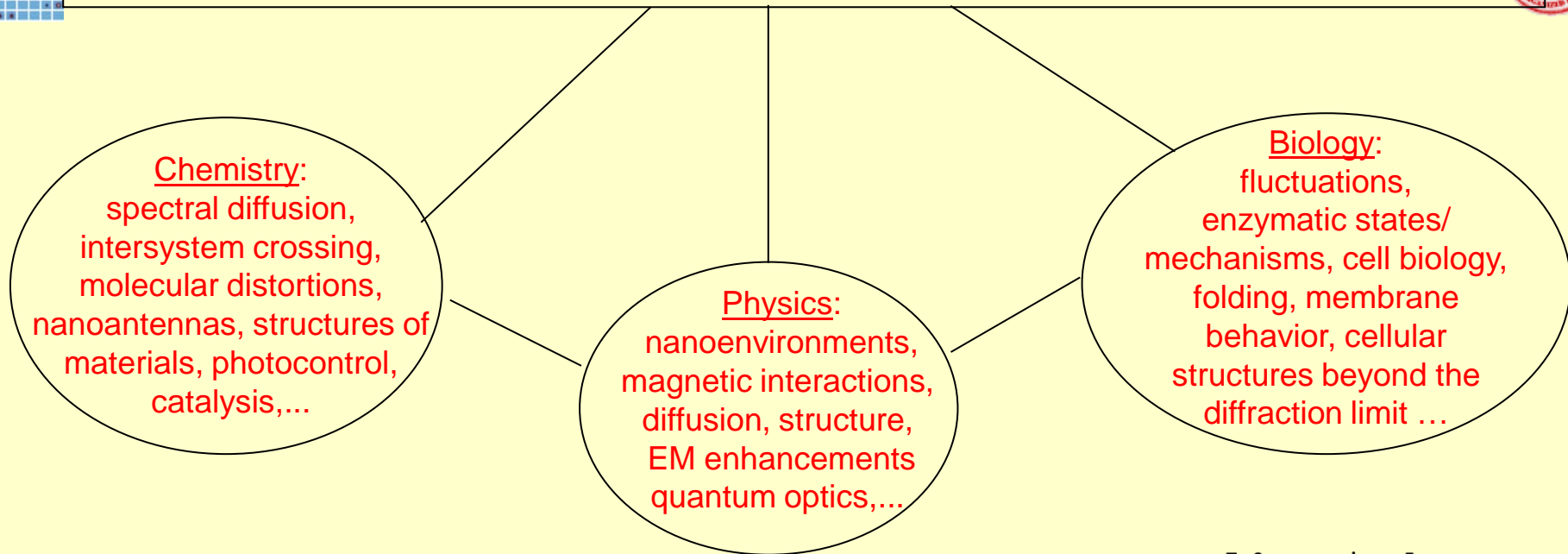

Working at the ultimate single-molecule limit has attracted the attention of many talented scientists around the world, who continue to make seminal contributions to this field!

FRET: TJ Ha, S Weiss ...

Enzymes: XS Xie, H Yang, ...

RNA folding, actin bands: X Zhuang, ...

Motors, DNA processing, DNA dynamics, gene expression, nuclear pores, RNA/proteins in cells, chaperonins, viral entry, quantum optics, new labels, 3D, ...

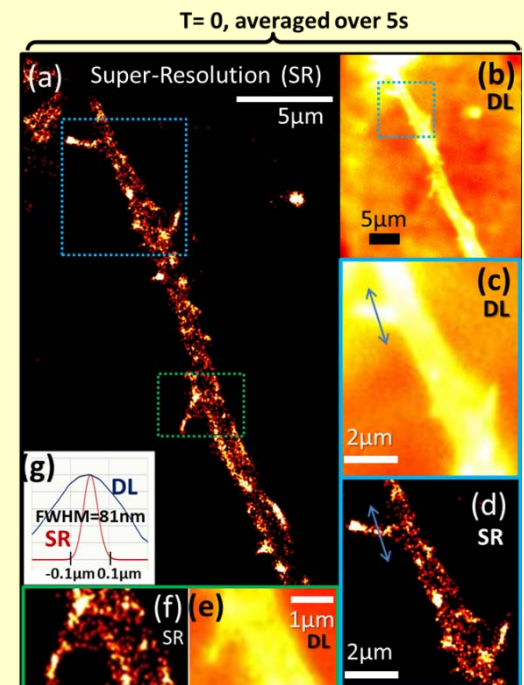
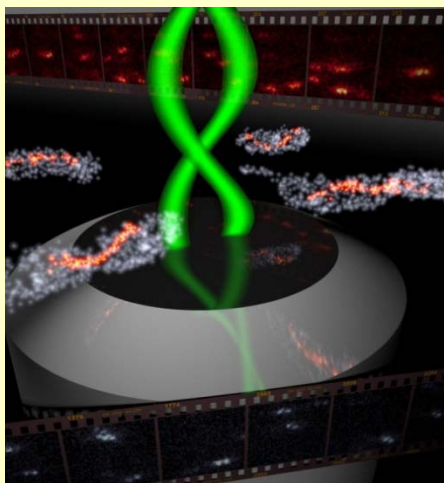

Thanks to Moerner Lab Alumni!



IBM Almaden Research Ctr., San Jose:

- Dr. Alan Huston
- Dr. Howard Lee
- Dr. Thomas Carter
- Dr. Lothar Kador
- Dr. W. Pat Ambrose
- Prof. Dr. Thomas Basché
- Prof. Anne Myers
- Dr. Paul Tchenio
- Dr. Jürgen Köhler
- Prof. Stephen Ducharme
- Dr. Peggy Walsh
- Dr. John Stankus
- Dr. Scott Silence
- Dr. Constantina Poga
- Dr. Yiwei Jia

University of California, San Diego:

- Ms. Courtney Thompson
- Dr. David J. Norris,
- Dr. Anders Grunnet-Jepsen
- Dr. Susanne Kummer
- Dr. Rob Dickson
- Dr. Maria Diaz-Garcia
- Mr. James Frazier
- Mr. Tim Marsh
- Ms. Julie Casperson
- Ms. Laura Neurauter
- Mr. Barry Smith

Stanford University:

- Dr. Erwin J. G. Peterman
- Dr. Arosha Goonesekera
- Dr. Sophie Brasselet
- Dr. Brahim Lounis
- Mr. Andre Leopold
- Mr. Erik Bjerneld
- Mr. Shaumo Sudhukhan
- Ms. Yeonsuk Roh
- Dr. Ueli Gubler
- Dr. Dan Wright
- Dr. Matt Paige
- Dr. Oksana Ostroverkhova
- Dr. Stephan Hess
- Dr. Marija Vrljic
- Dr. Jason Deich
- Mr. Johann Schleier-Smith
- Dr. Kallie Willets
- Dr. Hans-Philipp Lerch
- Dr. Stefanie Nishimura
- Dr. David P. Fromm
- Dr. P. James Schuck
- Ms. Jennifer Alyono
- Dr. Jaesuk Hwang
- Mr. Kit Werley
- Dr. Hanshin Hwang
- Mr. Naveen Sinha
- Dr. Adam E. Cohen
- Dr. Laurent Coolen
- Dr. Marcelle Koenig
- Dr. Andrea Kurtz
- Dr. So Yeon Kim
- Dr. Frank Jaeckel
- Ms. Nicole Tselentis
- Dr. Magnus Hsu
- Dr. Nick Conley
- Dr. Julie Biteen
- Dr. Sam Lord
- Dr. Shigeki Iwanaga
- Dr. Anika Kinkhabwala
- Dr. Alexandre Fuerstenberg
- Mr. Andrey Andreev
- Dr. Jianwei Liu
- Dr. Steven F. Lee
- Dr. Majid Badieirostami
- Dr. Randall Goldsmith
- Dr. Michael Thompson
- Dr. Hsiao-lu Denise Lee
- Ms. Yao Yue
- Dr. Whitney Duim
- Dr. Yan Jiang
- Ms. Katie Evans
- Dr. Lana Lau
- Dr. Sam Bockenhauer
- Dr. Andreas Gahlmann
- Dr. Steffen Sahl
- Dr. Gabriela Schlau-Cohen
- Dr. Matthew Lew
- Prof. Michael Börsch

More Thanks: The Current **Guacamole** Team!

Dr. Yoav Shechtman
Dr. Saumya Saurabh
Dr. Quan Wang
Dr. Allison Squires
Marissa Lee
Mikael Backlund
Lucien Weiss
Adam Backer
Alex Diezmann
Hsiang-yu Yang
Colin Comerci
Camille Bayas
Josh Yoon
Maurice Lee
Petar Petrov
Jingying Yue (rotator)



S. Lord

one molecule = one **guacamole**
(i.e., 1 over **Avocado's Number** of moles, $1/N_A$ moles)
(with apologies to the memory of Amadeo Avogadro)

Thanks to My Collaborators/Colleagues!

Washington University:

- Jan Brown, Harry Ringermacher, Marjorie Yuhas, ...

Cornell University

- Yves Chabal, Aland Chin, Andy Chraplyvy, Fred Pinkerton, Eric Schiff, Don Trotter, ...

IBM Research:

- Gary C. Bjorklund, Christoph Bräuchle (TU Munich), Don Burland, Bryan Kohler (Wesleyan), Bill Lenth, Marc Levenson, Roger MacFarlane, Chris Moylan, Michel Orrit (CNRS), Jan Schmidt (Leiden), Robert Shelby, Campbell Scott, Robert Twieg, ...

ETH Zürich:

- Bert Hecht, Thomas Irngartinger, Viktor Palm, Taras Plakhotnik, Dieter Pohl (IBM), Aleks Rebane, Urs P. Wild,

UCSD:

- Larry Goldstein, Jay Siegel, Susan Taylor, Mark Thiemens, Roger Tsien, Bruno Zimm, ...

Stanford:

- Thijs Aartsma (Leiden), Steve Boxer, Chris Calderon (Numerica), Gerard Canters (Leiden), Wah Chiu (BCM), Justin DuBois, Shanhui Fan, Gordon Kino, Eric Kool, Harden McConnell, Rafael Peistun (CU), Matthew Scott, Lucy Shapiro, Andy Spakowitz, Tim Stearns, Bob Waymouth, Karsten Weis (UCB), Paul Wender, and many more

Thanks to My Mentors, Homes, Funding Sources



Mentors:

- High School (Thomas Jefferson): Mrs. Blanche Rodriguez, Dr. Richard G. Domey (Bioengineering, UTMSSA)
- Undergrad (Wash U): James G. Miller
- Graduate (Cornell): Albert J. Sievers III
- Professional:
 - IBM: Gary C. Bjorklund, Dan Auerbach, Jerry Swalen, George Castro, Grant Willson
 - UCSD: Kent Wilson, Katja Lindenberg
 - Stanford: Harden McConnell, Dick Zare, Michael Fayer

JGM '75



AJS '81

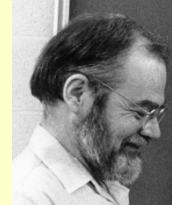

Funding: U. S. Agencies: ONR, NSF, NIH-NIGMS, NIH-NEI, DOE-BES



Institutions post PhD:

- IBM Research, San Jose and Almaden Research Centers
- ETH Zurich (Guest Professor of Urs P. Wild)
- The University of California, San Diego, Dept. Chemistry and Biochemistry
- Stanford University, Department of Chemistry
- Administrators and Staff, Administrative Assistants Kathi Robbins, Ann Olive

Thanks to My Family and Friends

Friends: Burr Stewart, Ed Snyder, Dave Palmer, and many, many more

In-Laws: Ruth and Michel Stein

Parents: William A. and Frances R. Moerner; Stepmother: Maria Esther Moerner



Wife and Son: Sharon S. Moerner and Daniel E. Moerner and my entire family!

