

Programmierbare Integrierte Schaltungen II

Application Specific Integrated Circuits (ASICs)

Me

Klaus-Peter Kirchner

University of Rostock
Faculty of Electrical Engineering and Information Technology

Contact:

Dr. Klaus-Peter Kirchner, Südstadt H III, Room 30
Phone 0381 498 7210
klaus-peter.kirchner@uni-rostock.de

Skript/Materials (several parts):

Stud-IP -> Course 24175 -> Documents

Campus Südstadt H III, Room S08 (WS-Pool)
Drive N:\asic1\...

www.igs.uni-rostock.de
-> Intranet (ITMZ-account) -> Skripte



History and Motivation



Developed in U.S. since 1981 (Initiated by US Department of Defense)

First Standard (IEEE-1076) in 1987

Revision in 1993 → VHDL-93

Revision in 2002 → VHDL-2002 (minor changes, relaxed buffer use)

Revision in 2008 -> VHDL-2008 (new generics, PSL)

Standard IEEE-1076.1 includes analog circuits (VHDL-AMS)

Property Specification Language
IEEE 1850 (Verification, Assertions)

Analog Mixed Signal

Description of digital hardware for simulation

Usable from gate to system level

Behavioural (and structural) description

Hardware independent

Portable

Top down and bottom up methodology supported

Readable ;-)

Synthesis tools became available (subset of VHDL)

VHDL in the Design Environment

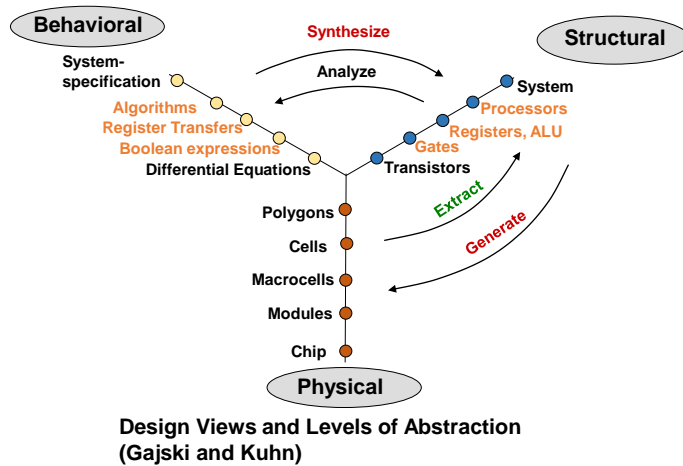

Simple FSM (Finite State Machine)

Z = X[1] and X[2]

→ CLK → X[2:0] → Y[1:0]

→ RESET → Z

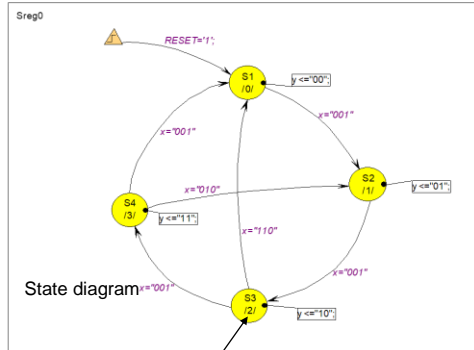

Later we learn how to influence encoding:
 ATTRIBUTE enum_encoding : STRING;
 ATTRIBUTE enum_encoding OF Sreg0_type : TYPE IS "00 01 10 11";

```

library IEEE;
use IEEE.std_logic_1164.all;

entity fsm1 is
port (CLK, RESET: in STD_LOGIC;
      X: in STD_LOGIC_VECTOR (2 downto 0);
      Y: out STD_LOGIC_VECTOR (1 downto 0);
      Z: out STD_LOGIC);
end entity fsm1;

architecture fsm1_arch of fsm1 is
type Sreg0_type is (S1, S2, S3, S4); --Enumeration type
signal Sreg0: Sreg0_type; --Signal defined by new type
begin
    Z <= X(1) and X(2);

    Y <= "01" when (Sreg0 = S2) else
        "10" when (Sreg0 = S3) else
        "11" when (Sreg0 = S4) else "00";

    Sreg0_machine: process (CLK)
    begin
        if CLK'event and CLK='1' then --if rising_edge(CLK)
            if RESET='1' then Sreg0 <= S1;
            else
                case Sreg0 is
                    when S1 => if x="001" then Sreg0 <= S2; end if;
                    when S2 => if x="001" then Sreg0 <= S3; end if;
                    when S3 => if x="110" then Sreg0 <= S1;
                                elsif x="001" then Sreg0 <= S4; end if;
                    when S4 => if x="010" then Sreg0 <= S2;
                                elsif x="001" then Sreg0 <= S1; end if;
                    when others => null;
                end case;
            end if;
        end if;
    end process;
end architecture;
    
```

Schematic and Structural VHDL

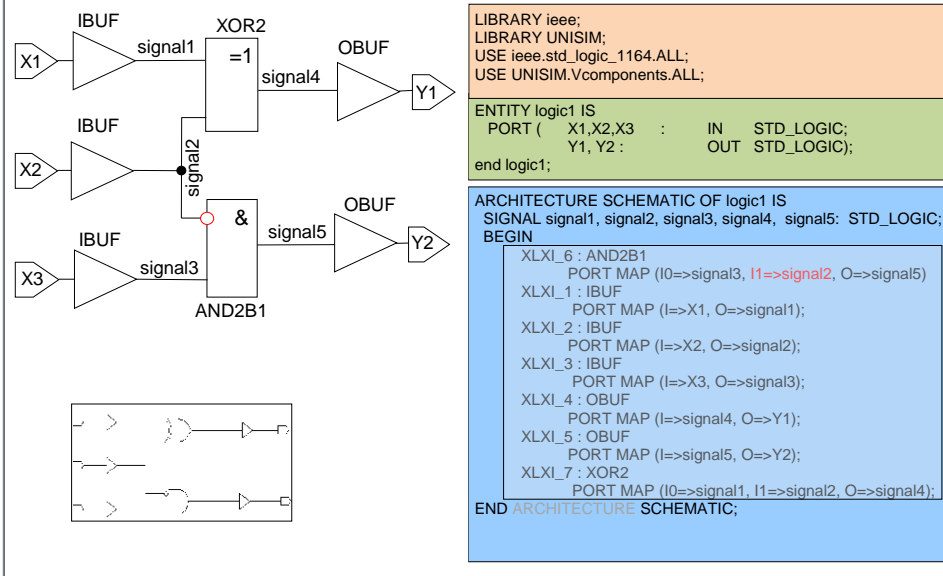

18/03/2019

Universität Rostock, IEF, Institut GS

9

Simulation: Logic Simulation Parallelism and Simulation Cycle

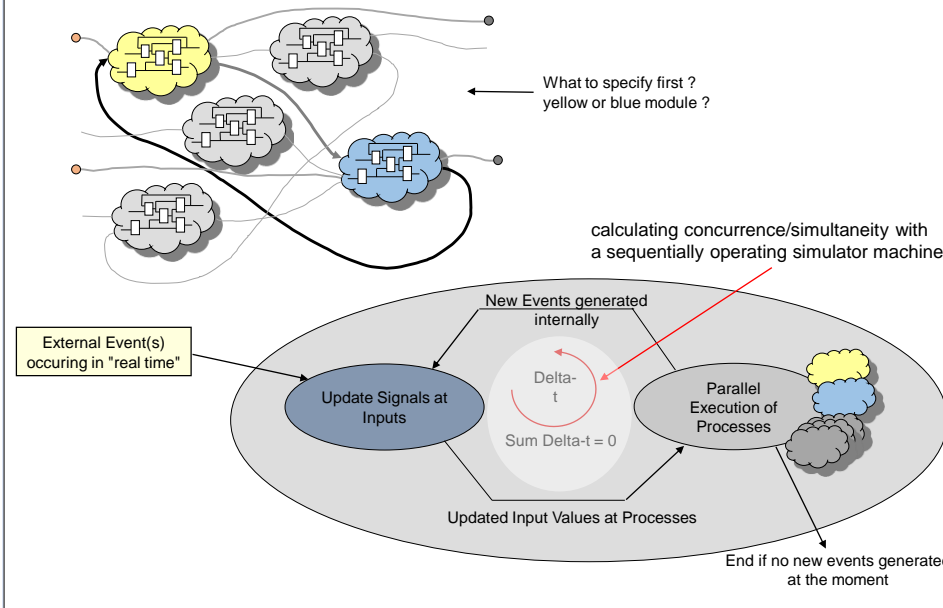

18/03/2019

Universität Rostock, IEF, Institut GS

10

Simulation: Logic Simulation Parallelism and Simulation Cycle

Activation of processes and new internal events

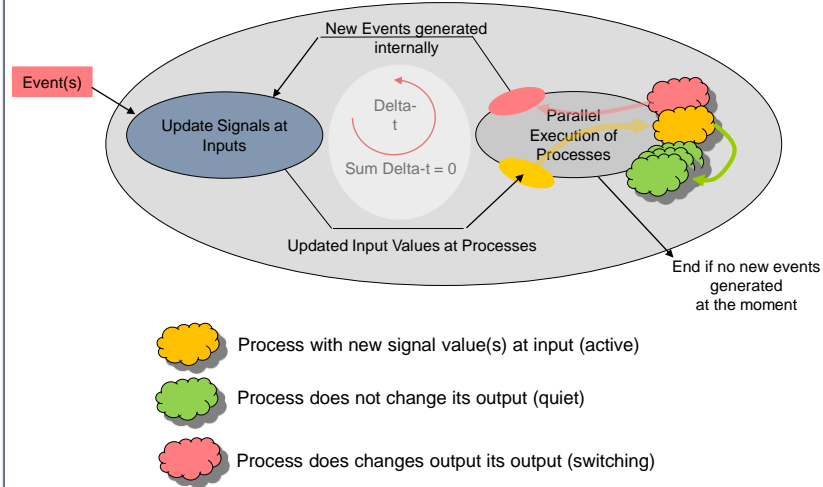

18/03/2019

Universität Rostock, IEF, Institut GS

11

Example: JK-MS-Flip-Flop

J	K	Q(n+1)
0	0	Q(n)
0	1	0
1	0	1
1	1	/Q(n)

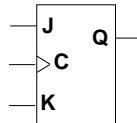

Q(n)	Q(n+1)	J	K
0	0	0	X
0	1	1	X
1	1	X	0
1	0	X	1

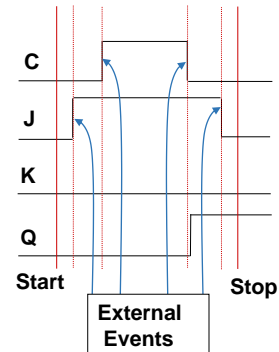

18/03/2019

Universität Rostock, IEF, Institut GS

12

Delay Models (Inertial)

Inertial Delay

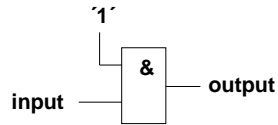

Typical behavior of **GATES**
Any pulse shorter than delay is not propagated to the output

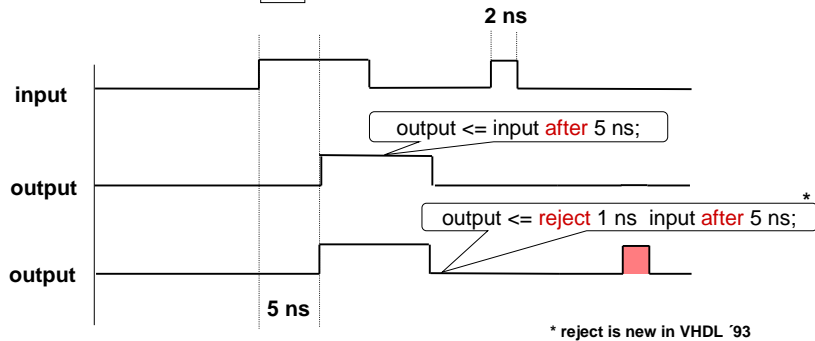

Behavior of Gates -> Inertial Delay

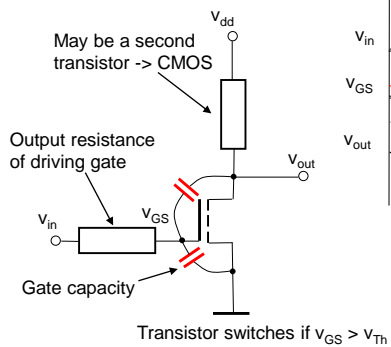

During the short pulse the threshold voltage V_{Th} is not reached and no output pulse is generated

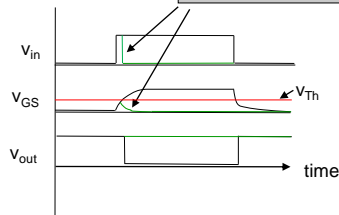

There is a problem beyond digital view:
What does happen with short high energy pulses?

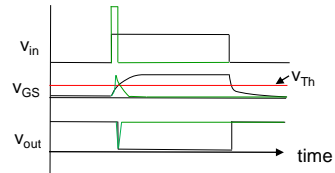

Delay Models (Transport)

Transport Delay

Typical behavior of **WIRES**
 Pulse shorter than delay is
 propagated to the output
 e. g. coax cable 5ns/m

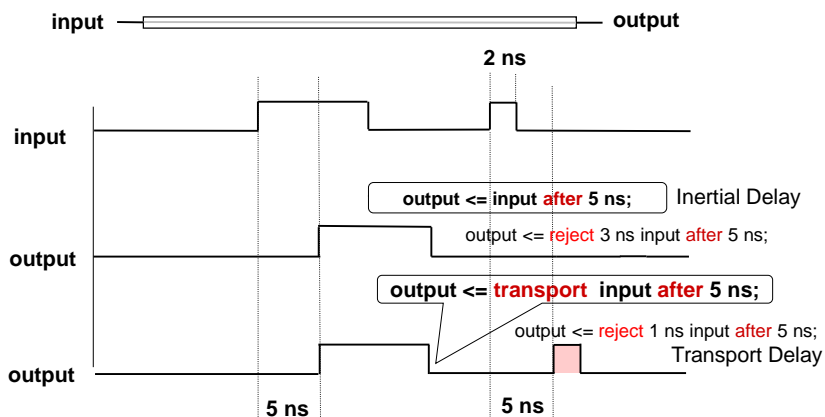

Design Entity

Entity Declaration

An **entity** can be a complex design like a CPU or even a simple gate

symbol

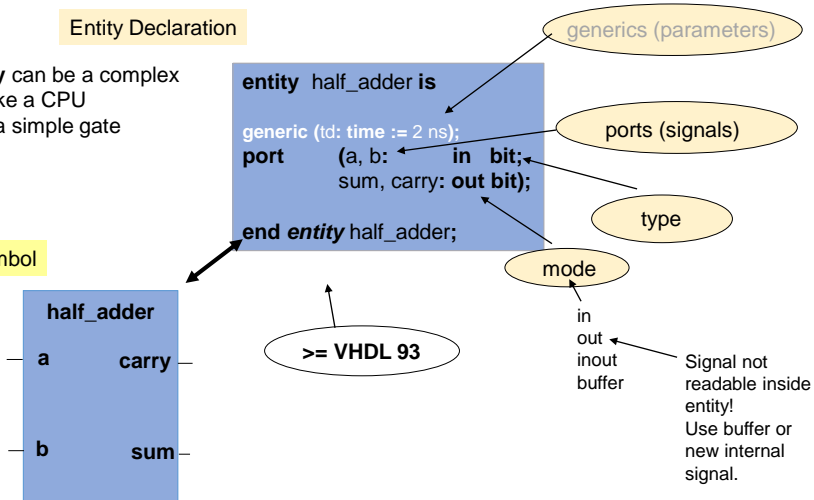

Port Modes

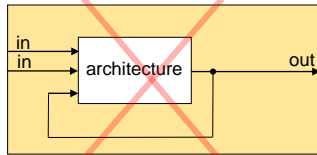

Port-Signal declared as „out“ cannot be read as an input

No longer restricted in VHDL 2008

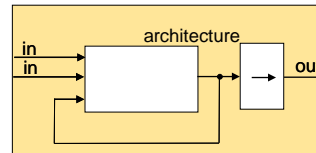

Defining a new (internal) signal for internal feedback

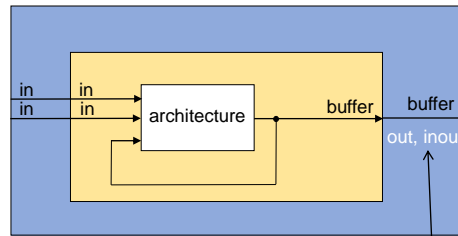

Mode „buffer“ must be used through hierarchy.

Beginning with VHDL-2002 connection to out, inout possible.

Architecture

What is the behaviour or structure of the entity ?

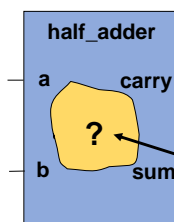

```
entity half_adder is
port
(a, b: in bit;
sum, carry: out bit);
end entity half_adder;
```

```
architecture simple of half_adder is
begin
sum <= a xor b;
carry <= a and b;
end architecture simple;
```

Place for internal declarations

An entity can have more than one architecture. When the entity is used the architectures may be selected by configurations. The architecture is the internal implementation of an entity. Synthesis tools will implement exactly one architecture.

Some Syntactical Rules: Identifiers, Comments, Instructions

VHDL is not case-sensitive, but remember that UNIX is !

and Verilog is!

HALF_ADDER and **half_adder** are the same in VHDL, but when in an UNIX-environment files are created using these identifiers UNIX scripts will distinguish between files **half_adder** and **HALF_ADDER** !

Scripts may become confused ..

x, **x1**, **x_1** are legal identifiers

x_, **1x**, **x-1** are illegal identifiers

VHDL key words must not be object identifiers

Example: **in** and **out** are illegal identifiers because they are port modes defined in VHDL, but **in0** or **out_1** are legal.

-- (two horizontal bars, hyphens) start a comment in VHDL

Some programs use special commands for flow control

Example: -- **pragma translate off/on** in SYNOPSIS

VHDL instructions may extend a line

/* */ in VHDL 2008 possible like in C and other languages

Instructions are closed by the ; semicolon character

Some Syntactical Rules: Extended Identifier (VHDL 93)

VHDL 93 provides „Extended Identifiers“

Enclosed in backslash

Case sensitive!

May contain special characters

May be reserved VHDL keywords

May start with a number

Allows keeping identifiers after translation from other languages or netlists

Examples:

\signal number 1\	with space
\1signal\	starting with a number
\in\	keyword in VHDL
\flip&flop\, \FLIP&FLOP\	special character included

Some Syntactical Rules: Literals

Values directly specified in the description

INTEGERS:	DECIMAL	2561		
	HEXA	16#A01#		
	OCTAL	8#5001#		
	BINARY	2#1010_0000_0001#	(underscore for readability)	
		With Exponent: = 2#11#E8 = $3 \cdot 2^8 = 768$		
FLOATING POINT:		3.141	(period indicates: floating point)	
		1.23E-3	(exponential)	
		With Exponent: = 16#A.01#E2 = $(10 + \frac{1}{256}) \cdot 16^2 = 2561$		
CHARACTERS:		'A'	(single quotation marks)	
STRINGS:		"Abcd efg"	(quotation marks) <small>String in string: Double quotation marks "ab"abc""</small>	
BIT STRINGS		B"10100010"	or simply "10100010"	
		X"A2"	(hexa) or O"242"	(octal)
PHYSICAL:		127 ns	(value, <u>space</u> , unit)	
		230 V		

18/03/2019

Universität Rostock, IEF, Institut GS

23

Some Syntactical Rules: Labels

Many VHDL units like process, loop, procedure, but also simple instructions in VHDL93 and newer can have a label for identification:

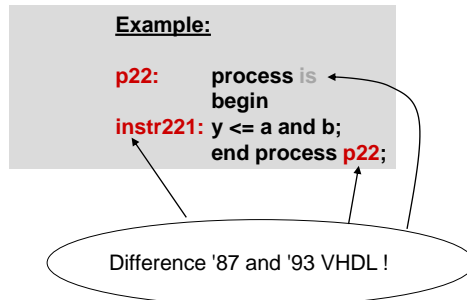

And sometimes it is advisable to use labels. Helps to identify code during debugging in simulation.

18/03/2019

Universität Rostock, IEF, Institut GS

24

Objects

Classes of Objects in VHDL (digital)

- Signals** Representation of wires in hardware.
New value is always assigned "in the future", when all processes are finished for the actual simulation cycle
- Variables** (including files VHDL'87)
Useful for computation
Get their new value immediately after assignment.
- Constants** Value is assigned at declaration only
- Files** (VHDL'93 and newer)

- Quantities** (VHDL-AMS)
floating TYPE
voltage or current
- Terminals** (VHDL-AMS)

electrical – voltage, current
thermal – temperature, heat(power) flow
translational – displacement, force
fluidic – pressure, flow rate

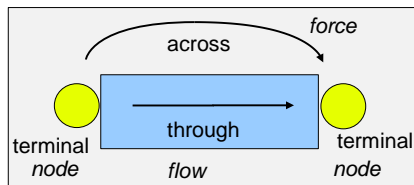

18/03/2019

Universität Rostock, IEF, Institut GS

25

Operators

	power function	remainder (sign of dividend) modulus (sign of divisor)
highest		** , abs , not
	Arithmetic:	* , / , mod , rem (remainder)
	Signs:	+ , -
	Arithmetic:	+ , - , & (concatenation)
	Shift/Rotate:	sll , srl , sla , sra , rol , ror
	Compare:	= , /= , < , > , <= , >=
	Logical (binary):	and , or , nand , nor , xor , xnor
lowest		

- sll/srl: Shift logical (include MSB)
- sla/sra: Shift arithmetical (excl. MSB)
- rol/ror: Rotate left/right

Do not use the shift operators.
Use functions like **shift_right**, **shift_left**
from package IEEE.Numeric_STD or use slices.

concatenation operator is & (for 1-dimensional arrays incl. strings)

"abc" & 'd' is "abcd" and ('0','1') & B"001111" is "0100_1111" or ('0','1','0','0','1','1','1','1')

Join strings Join bit vectors

18/03/2019

Universität Rostock, IEF, Institut GS

26

Operators

New operators in VHDL 2008

Matching Compare
Don't care '1' at one input
possible

```
cs >= '1' when addr(19 downto 12)=X"0F" else '0';
cs <= addr ?= X"0F--";
```

Matching Compare: `?=, ?/=, ?<, ?>, ?<=, ?>=`
Logical (unary): `and, or, nand, nor, xor, xnor`
Condition Conversion: `??`
maximum, minimum, to_string, rising_edge, falling_edge

Confusing, because often seen in older descriptions ->
available from additional libraries -> now native VHDL

Type: bit

`Y <= and X;`

If `??(a and b)` then

`Y = x ?>= "1001";`

If X is a bit-vector, the result is the and-function of its elements. The result type is bit, std_ulogic.

If a, b are of bit or std_logic type, ?? converts result to boolean -> **See next slide!**

If x is greater than "1001" the result Y will be '1', not "true"
Argument types: bit, std_ulogic or vector of them only

`Podd <= xor Y;` -- Podd = 1, when bit or std_logic vector Y has odd parity (odd number of '1' values)

18/03/2019

Universität Rostock, IEF, Institut GS

27

Bit and Boolean

Predefined types in VHDL

type bit is ('0','1');

signal s1: bit;

WORKING: if s1= '1' then ..

NOT WORKING: if s1 then ..

type boolean is (false,true);

signal s2: boolean;

WORKING: if s2 then ..

WORKING: if s2 = true then

NOT WORKING: if s2 = '1' then ..

Condition conversion in VHDL 2008
?? sig1 converts '0' and '1' to false and true
Automatically without operator in new version?

18/03/2019

Universität Rostock, IEF, Institut GS

28

Operators (Comparison VHDL <-> Verilog]

	VHDL	Verilog
logical	not, and, or, xor ..	~, &, , ^
shift	sll, sla ...	a<<1, a<<<1
concatenation	a & b	{a,b}
unary reduction	y <= and x;	y <= &x;

Object Declaration (Signals)

```

signal z_internal: bit;
signal state: main_state_type := idle;
signal counter: integer range 0 to 127 := 0;
    
```

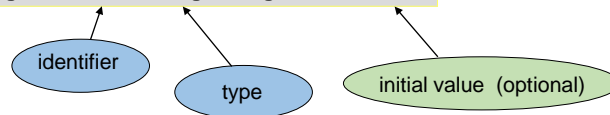

Initial values for simulation,
Declaring an initial value will NOT
include reset hardware in synthesis !!

If we **know** that the hardware (FPGA) sets all flip-flops to '0' at poweron it may be a good idea to presume this fact in our design and to help the simulator to start with the proper value, using an initial value!

Remember: Signals may also be declared in entity declarations (inputs and outputs)

Object Declaration (Constants and Variables)

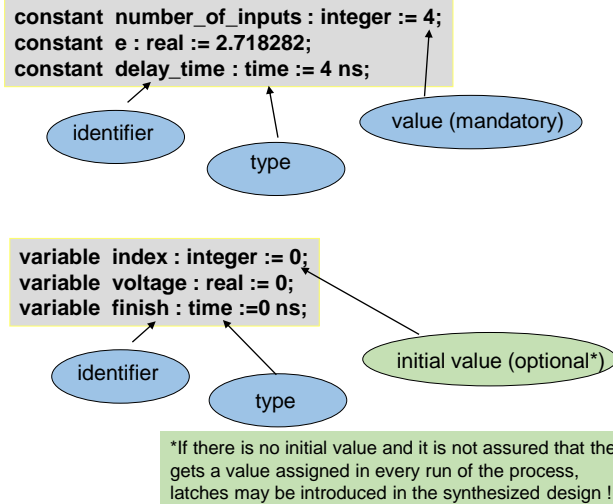

Concurrent and Sequential View

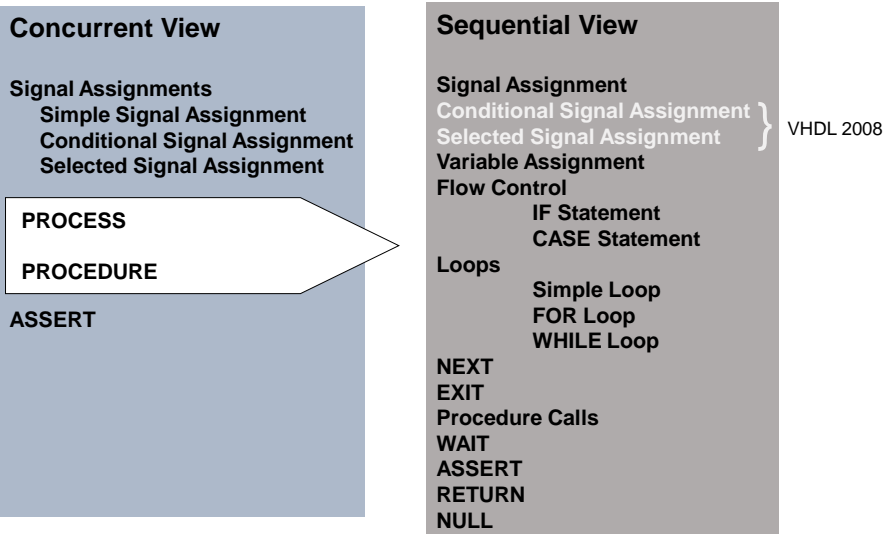

Concurrent Signal Assignment - CSA

Simple Signal Assignment

```

u <= a and b;
v <= (a or c) after 5 ns;
w <= '1', '0' after 10 ns, '1' after 20 ns;
    
```

<= "is defined to be"

Not an equation. We cannot swap/transpose both sides. Hardware is (mostly) unidirectional.
Exception: Transmission Gates (No operator, but instantiation possible)

Usually a signal must not have more than one driver, Only one CSA can assign a value to a signal.

Signals with more than one driver --> **RESOLVED SIGNALS**

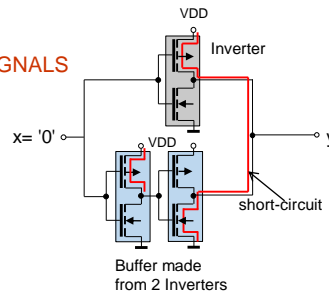
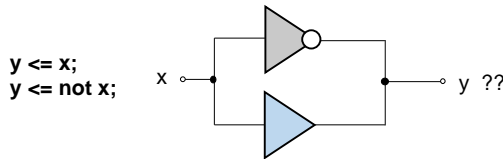

18/03/2019

Universität Rostock, IEF, Institut GS

33

Resolved Signals

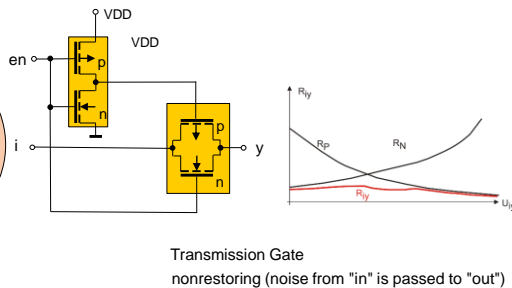
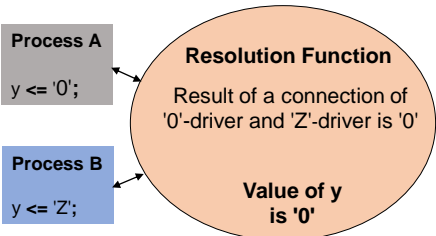
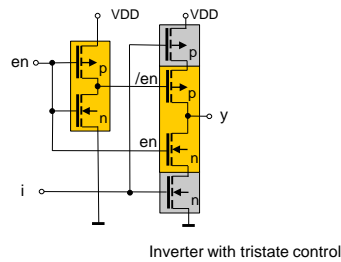
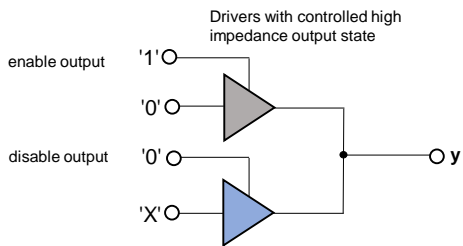

18/03/2019

Universität Rostock, IEF, Institut GS

34

Concurrent Signal Assignment - CSA

Conditional Signal Assignment

```
y <= a after 5 ns when input = 0 else
     b when input = 1 else
     c when input = 2 else
     d when input = 3
     else 'X' ;
```

choice selector: integer

Selected Signal Assignment

```
with input select y <= a after 5 ns when "00",
                     b when "01",
                     c when "10",
                     d when "11",
                     'X' when others ;
```

choice selector: bit_vector

Possible keyword **unaffected** in VHDL '93

sequential logic (latches)!

Process (combinatorial, sensitivity list / wait)

Process construct allows sequential statements inside.
Process is one CSA in the description (or: every CSA is a process)

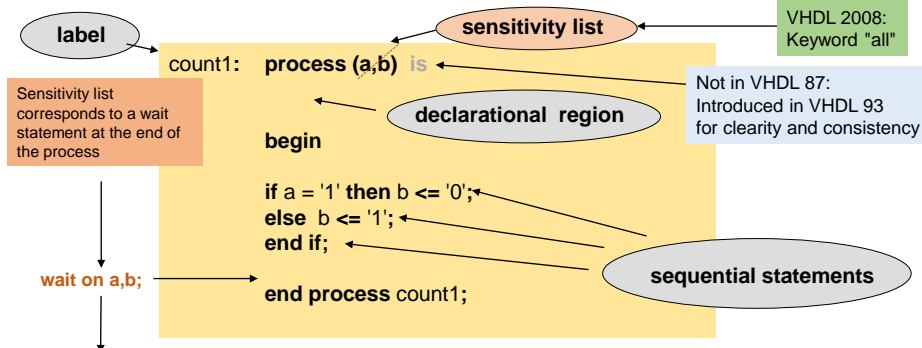

Process is executed whenever an event at a signal mentioned in the sensitivity list occurs. (and waits just before the end statement)

Process must have a sensitivity list or wait statements for execution control, but not both together !!

Process (sequential, sensitivity list)

Process construct allows sequential statements inside.
Process is one CSA in the description (or: every CSA is a process)

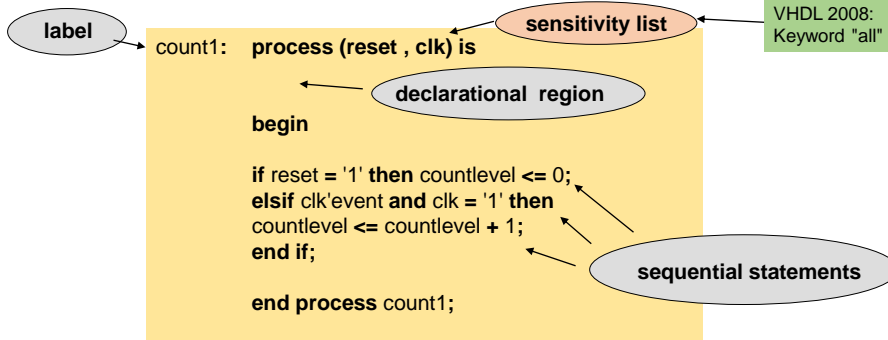

Process is executed whenever an event at a signal mentioned in the sensitivity list occurs (and waits just before the end statement)

Process must have a sensitivity list or wait statements for execution control, but not both together !!

Process (sequential, wait statement)

Process construct allows sequential statements inside.
Process is one CSA in the description (or every CSA is a process)

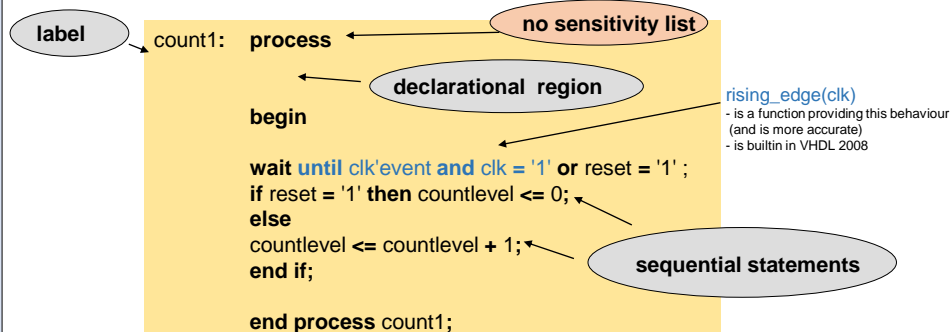

Process with no sensitivity list is executed forever.

To achieve an advance in time there must be a wait statement if there is no sensitivity list.

Process must have sensitivity list or wait statements for execution control, but not both together !!

Sensitivity list is equivalent to a wait statement at the end of the process (if they concern the same signals, events).

Signal Assignment

VHDL 2008:
Selected an Conditional allowed

Signal Assignment (simple only)

```
u <= a and b;  
v <= (a or c) after 5 ns;  
w <= '1', '0' after 10 ns, '1' after 20 ns;
```

Inside a process multiple assignments to the same signal are possible.
Last assignment executed will give the result (after end of all processes).

Variable Assignment

```
v := a and b;
```

Only inside a process*.
Assignment is processed immediately. Value stored from process call to process call. -> If not initialized before first use in process -> Latch or Flip-Flop

Process as Concurrent Statement/ Concurrent Statement as Process

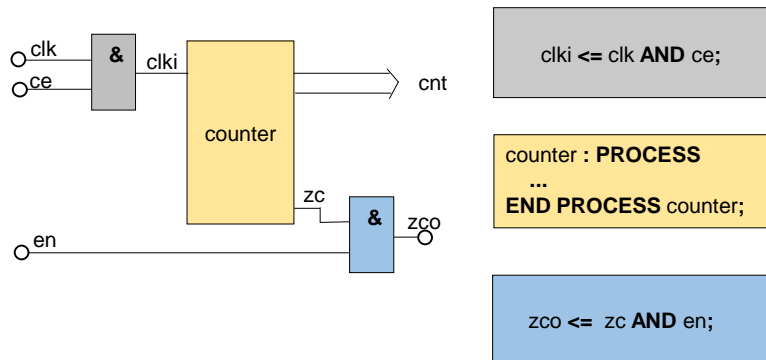

IF (sequential)

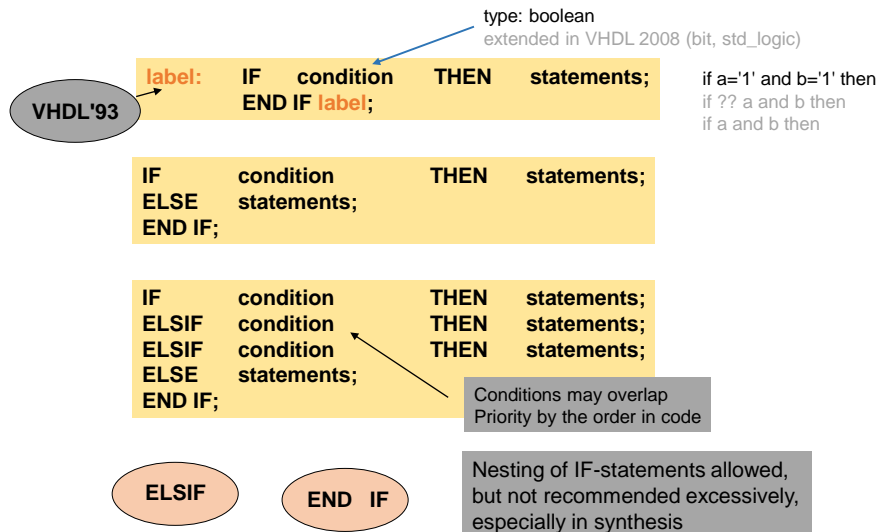

Target hardware: priority encoder

18/03/2019

Universität Rostock, IEF, Institut GS

41

Case (sequential)

Control flow by the value of an expression

```

label: CASE object IS
  WHEN value1 => statements;
  WHEN value2 => statements;
  WHEN value3 | value4 => statements;
  WHEN value5 TO value7 => statements;
  WHEN OTHERS => statements;
END CASE label;
    
```

VHDL 2008: expressions
instead of single objects
allowed

VHDL 2008: Matching case
case? expression is
when "--00" =>

Choices mustn't overlap. Must be "locally static".
All possible values for expression must be represented as choices!

Different behavior
in Verilog (default is optional,
overlap is allowed)

Value1 or value 2 value1 | value2
Using a RANGE of choices value1 TO / DOWNT0 value2
Referencing all values, not used yet OTHERS

Range must be defined.
Is not for bit-vectors!
Is for integer, enumeration

If you need a branch with no action use the **NULL**-statement

Target hardware: multiplexer

18/03/2019

Universität Rostock, IEF, Institut GS

42

Case (example)

Signal count runs cyclic from 0 to 137 with an output pulse of '1' at zero_out while the signals value is 0.

```
SIGNAL count : INTEGER RANGE 0 TO 137;  
SIGNAL zero_out : BIT;
```

```
WAIT UNTIL clk'EVENT and clk='1';
```

```
counter138:  
CASE count IS  
  WHEN 0      => count <= count + 1;  
                zero_out <= '0';  
  WHEN 1 TO 136 => count <= count + 1;  
  WHEN 137    => count <= 0;  
                zero_out <= '1';  
  WHEN OTHERS => count <= 0;  
                zero_out <= '1';  
                report ("unexpected value for count");  
END CASE counter138;
```

Loop (sequential)

Simple Loop

```
Label: LOOP  
  statements  
  EXIT label WHEN condition;  
  END LOOP label;
```

In all loops

EXIT statement must be executed or WAIT included

For Loop

```
Label: FOR loop_variable IN range LOOP  
  statements  
  END LOOP label;
```

Integer, implicit declaration

Stepsize 1

```
0 TO 10      15 DOWNTO 1  
V'LOW TO 15 V'HIGH DOWNTO 0  
V'RANGE     V'REVERSE_RANGE  
A'RANGE(2)  A'REVERSE_RANGE(1)
```

While Loop

```
Label: WHILE condition LOOP  
  statements  
  END LOOP loop_label;
```

Condition must become FALSE during loop execution or EXIT statement must be executed or WAIT included

!Synthesis!

Loops (example)

The signals input and output are vectors with elements of the (self defined) type bit4v.

```
TYPE bit4v IS ('X', '0', '1', 'Z');
```

```
example: PROCESS (input)
  VARIABLE result : bit4v := '1';
BEGIN
  result := '1';
  FOR i IN input'RANGE LOOP
    CASE input(i) IS
      WHEN '0' => result := '0' EXIT;
      WHEN 'X' => result := 'X' NEXT;
      WHEN 'Z' | '1' => NULL;
    END CASE;
  END LOOP;
  output <= result;
END PROCESS example;
```

Loop works in area, not in time!

'0' is dominant value

exit loop

change nothing

next cycle

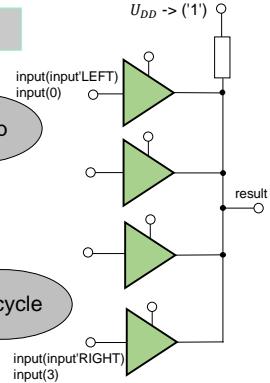

-> input(input'RANGE is: 0 to 3)

Multiplexing the inputs with a wired_or FUNCTION using open-drain outputs.

Loop in Programming and Hardware Description Languages

Programming Language

```
for i in 0 to 3 loop
  if dig_array(i) = 9 then dig_array(i) <= 0;
  next;
  else dig_array(i) <= dig_array(i) + 1;
  exit;
end if;
end loop;
```

Hardware Description Language

```
if rising_edge(clk) then
  for i in 0 to 3 loop
    if dig_array(i) = 9 then dig_array(i) <= 0;
    next;
    else dig_array(i) <= dig_array(i) + 1;
    exit;
  end if;
  end loop;
end if;
```

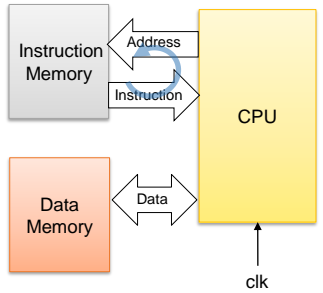

multiple clock cycles, dependent on state (overflow or not)

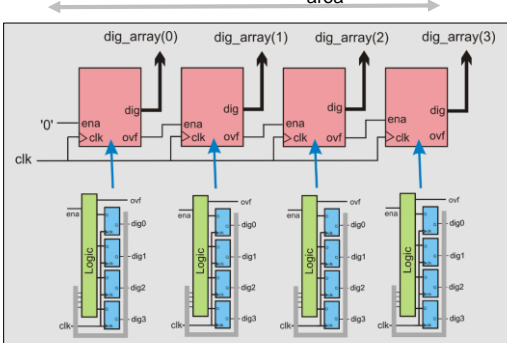

One clock cycle

Wait Statement (Sequential)

WAIT suspends a process

WAIT; suspends until end of simulation

WAIT ON list of signals; an event at one of the listed signals reactivates the process

WAIT UNTIL condition; process is suspended until condition = TRUE

WAIT FOR time; process is suspended for the given time

WAIT UNTIL sig1 = '1' **FOR** 1 us; (condition TRUE or TIMEOUT)
WAIT ON a **UNTIL** b = '1'; (b tested whenever event at a)
WAIT UNTIL (clk'event AND clk = '1'); (wait for rising clock edge)

Procedure Call

- Subroutine with sequential statements
- Procedures can change the values of their input objects

label: identifier (association list);

Examples with different kinds of association lists:

Positional: add (x1 , x2 , y , c);
Named: add (term1 => x1, carry => c, sum => y, term2 => x2);

PROCEDURE add
(term1, term2: IN bit_vector;
sum: OUT bit_vector;
carry: OUT bit) IS

Named association: locals => actuals

In synthesis every procedure call invokes a new instance of hardware !

Procedure

- Subroutine with sequential statements
- Can change the values of its input objects

```
PROCEDURE add (term1, term2: IN bit_vector;  
              sum: OUT bit_vector;  
              carry: OUT bit) IS  
Variable c: bit := '0';  
BEGIN  
  FOR i IN term1'REVERSE_RANGE LOOP  
    sum(i) <= term1(i) XOR term2(i) XOR c;  
    c := (term1(i) AND term2(i)) OR ... ;  
  END LOOP;  
  carry <= c;  
END PROCEDURE add;
```

term1, term2, sum must be of same dimension in this example.

Unconstrained ARRAY parameter possible.
Default values possible.

Procedure Example I

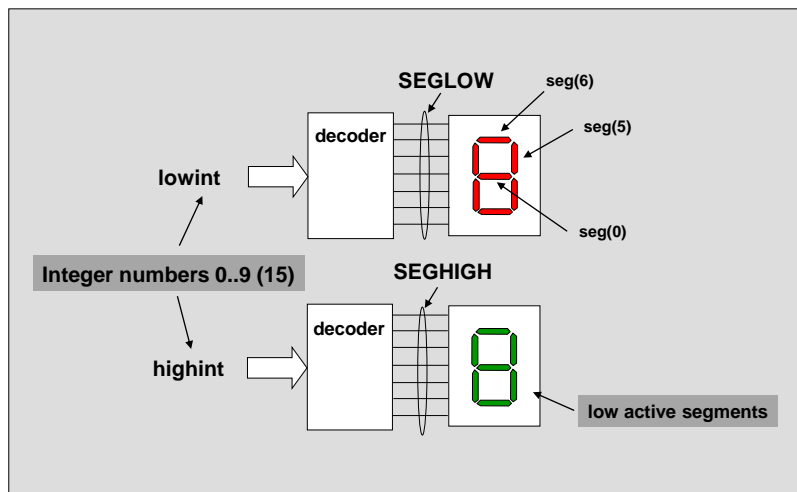

Procedure Example II

```
procedure decode(signal dig: in integer range 0 to 15;
                 signal seg: out std_logic_vector(6 downto 0)) is
begin
    case dig is
        when 0 => seg <= "0000001";
        when 1 => seg <= "1001111";
        ..
        when 8 => seg <= "0000000";
        when 9 => seg <= "0000100";
        when others => seg <=
"1111111";
    end case;
end procedure decode;

begin
    decode (lowint, SEGLOW);
    decode (highint, SEGHIGH);
```

18/03/2019

Universität Rostock, IEF, Institut GS

51

Assert and Report

ASSERT is used to check expressions during simulation.

```
ASSERT condition  
REPORT message  
SEVERITY level;
```

Default message without REPORT:
"assertion violation"

Default value : ERROR

Strenge, Schärfe

Severity levels
NOTE
WARNING
ERROR
FAILURE

If condition is TRUE then do nothing, else print the message when the severity level is equal or higher than the level selected in the simulator.

Report can be used standalone.

18/03/2019

Universität Rostock, IEF, Institut GS

52

Assert (example)

```

ASSERT R or S = '1'
REPORT "R and S are both 0 "
SEVERITY warning;
    
```

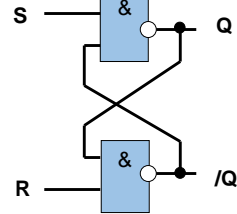

```

ASSERT input_char >= '0' and input_char <= '9'
REPORT "Input is not a digit!"
SEVERITY note;
    
```

Function

A Function is used in place of an expression or value.

pure : Does not depend on external values. Every call with same inputs gives the same output. (default)

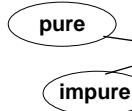

```

FUNCTION identifier (interface_list) RETURN TYPE IS
    declarations;
BEGIN
    sequential statements;
    RETURN value;
END FUNCTION identifier;
    
```

impure : FUNCTION depends on external values. Every call can give different output even with the same inputs

```

FUNCTION limit (actual, max, min: integer) RETURN integer IS
BEGIN
    IF actual > max THEN RETURN max;
    ELSIF actual < min THEN RETURN min;
    ELSE RETURN actual;
    END IF;
END FUNCTION limit;
    
```

```

Y <= limit (x, 126 , 17 );
    
```

Function Example from Cnt9999 Lab

```
FUNCTION int7seg (digit:integer range 0 to 9) RETURN std_logic_vector  
  
variable dout: std_logic_vector(0 to 6);  
begin case digit is -- "abcdefg"  
  when 0 => dout := "0000001";  
  when 1 => dout := "1001111";  
  when 2 => dout := "0010010";  
  when 3 => dout := "0000110";  
  when 4 => dout := "1001100";  
  when 5 => dout := "0100100";  
  when 6 => dout := "0100000";  
  when 7 => dout := "0001111";  
  when 8 => dout := "0000000";  
  when 9 => dout := "0000100";  
  when others => dout := "1111111";  
end case;  
return dout;  
end function int7seg;
```

```
SEG <= int7seg(dig_array(i));
```

NEXT, EXIT, RETURN, NULL

By using **NEXT** execution continues at the bottom of the LOOP-statement.

By using **EXIT** a loop will be left. Simple loops can only be left by this command. Loop_level allows to leave outer loops from internal loops in nested loop constructions.

```
EXIT loop_label WHEN condition;  
EXIT loop_label;  
EXIT WHEN condition;  
EXIT;
```

RETURN is used to leave subroutines. A Procedure can be left by simply using **RETURN**;
A Function cannot alter the value of its input objects. The RETURN statement has to return a value.

```
RETURN value;
```

The **NULL** statements can be used as a placeholder in arms of trees where no activity is wished:

```
NULL;
```

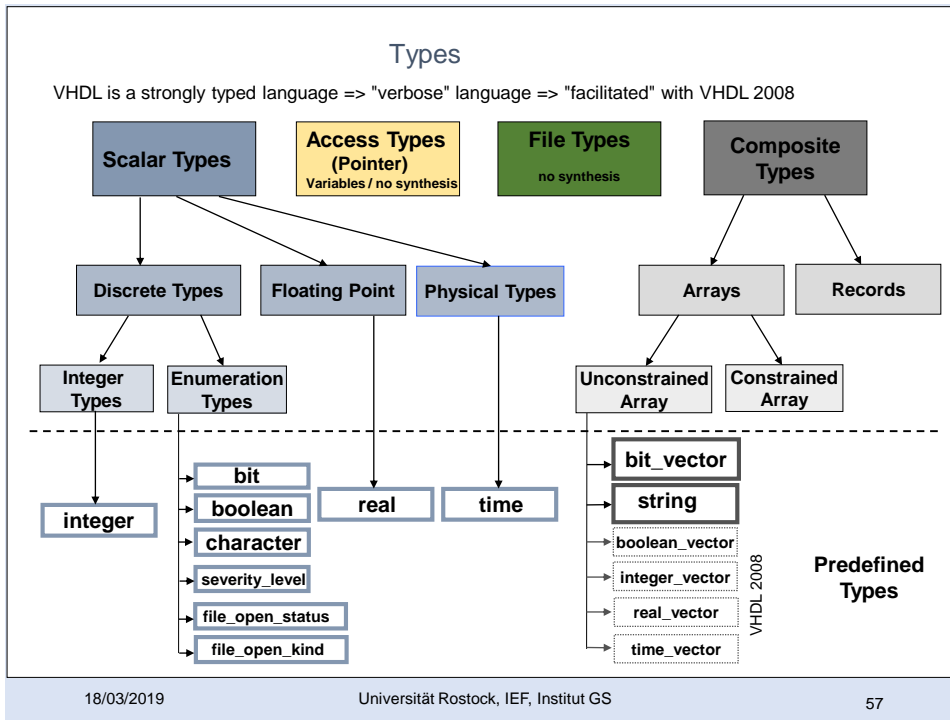

Scalar Types

Integer	Floating Point	Enumeration	Physical	(Files)
---------	----------------	-------------	----------	---------

Type Declaration:
TYPE type_identifier **IS** type_definition;

Examples:

TYPE my_real	IS	Range -5.0 to 5.0;		
TYPE my_integer	IS	Range -128 to 127;		
TYPE my_logic	IS	('X','Z','0','1');		
TYPE color	IS	(red, green, blue);	}	Enumeration
TYPE state_type	IS	(reset, receive, send, wait);		
TYPE severity_level	IS	(note, warning, error, failure)		

Integer is predefined (min.) -2,147,438,648 to 2,247,483,647 -> 32 Bit
Real is predefined (min.) -1.0E+38 to 1.0E+38 (32 Bit with 6 digits precision)

! A signal declared as an integer type has 32 bits --> Synthesis !

18/03/2019 Universität Rostock, IEF, Institut GS 58

Scalar Types (Time)

Physical Type **TIME** is predefined

```
TYPE time IS RANGE -(2**31) to 2**31-1
units
  fs;
  ps = 1000 fs;
  ns = 1000 ps;
  us = 1000 ns;
  ms = 1000 us;
  sec = 1000 ms;
  min = 60 sec;
  hr = 60 min;
end units;
```

tool dependent

! There is a space between value and unit **127 ns**
0.127 us

Scalar Types (Physical Types)

```
TYPE resistance IS RANGE 0 to 1E9
units
  ohm;
  kohm = 1000 ohm;
  Mohm = 1000 kohm;
end units;
```

Integer values only!

```
TYPE length IS RANGE 0 to 1E9
units
  um;
  mm = 1000 um;
  m = 1000 mm;
  inch = 25400 um;
  ft = 12 inch;
end units;
```

-- primary unit is micron

Composite Types (Arrays I)

Arrays contain elements of unique type

Constrained Array:

```
TYPE word IS ARRAY (31 DOWNT0 0) OF bit;
TYPE color IS (red, green, blue, magenta, yellow, cyan);
TYPE color_table_type IS ARRAY (color) OF bit;
TYPE three_color IS ARRAY (color RANGE red TO blue) OF bit;
```

Element Type

```
TYPE intmatrix IS ARRAY (1 TO 10, 1 TO 20) OF integer;
```

```
TYPE raw, col IS RANGE 1 TO 1024;
TYPE pix_mat IS ARRAY (raw, col) OF bit;
```

2-dimensional

Unconstrained Array:

```
RANGE <> -- <> box, replaced by a range in object declaration
```

Predefined in VHDL:

```
TYPE bit_vector IS ARRAY (natural RANGE <>) OF bit;
TYPE string IS ARRAY (positive RANGE <>) OF character;
```

18/03/2019

Universität Rostock, IEF, Institut GS

61

Composite Types (Arrays II)

Declaration of objects:

Constrained Array:

```
SIGNAL my_word_sig : word;
SIGNAL color_table: color_table_type;
```

Box <> replaced by range specification

Unconstrained Array:

```
SIGNAL vec_sig1: bit_vector ( 0 TO 31);
SIGNAL vec_sig2: bit_vector (7 DOWNT0 0);
SIGNAL my_string: string (1 TO 20);
```

Referencing Arrays, Slices, Elements:

```
bit
  y <= vec_sig1(13); -- A single element;
  z <= color_table( green ); -- Index is enumeration type;
vec_sig2 <= vec_sig1( 0 TO 7 ); -- A slice of the array;
vec_sig1 <= vec_sig2; -- Vectors of same dimension;
vec_sig1( 0 TO 9 ) <= vec_sig2 ( 9 DOWNT0 0); -- Reverse index connection;
```

18/03/2019

Universität Rostock, IEF, Institut GS

62

Composite Types (Usage of unconstrained Arrays)

```
-- Two constrained array types
TYPE intarray10 IS ARRAY (0 TO 9) OF integer;
TYPE intarray20 IS ARRAY (0 TO 19) OF integer;
```

```
-- Declaring signals using two different types
SIGNAL signal1, signal2 : intarray10;
SIGNAL signal3          : intarray20;
```

```
--Error in assignment, type mismatch
signal3 <= signal1 & signal2;
```

```
-- One unconstrained array type
TYPE intarray IS ARRAY (natural range <=>) of integer;
```

```
--Declaring signals using the same type with different constraints (length)
SIGNAL signal1, signal2 : intarray (0 to 9);
SIGNAL signal3 :          intarray (0 to 19);
```

```
--OK., because all operands are of the same type
signal3 <= signal1 & signal2;
```

18/03/2019

Universität Rostock, IEF, Institut GS

63

Composite Types (Arrays III)

Content of Arrays (Aggregates):

Positional Association:

```
SIGNAL my_vector: bit_vector ( 0 TO 7);
```

Position 0 Position 7

```
my_vector    <= ('0', '1', '0', '0', '0', '0', '0', '0');
my_enu_vec   <= (red , red, red, blue, yellow, green);
my_int_vec   <= ( 1 , 25 , 34 , 112 );
```

For 1-dimensional bit vectors: Bit strings

```
my_vector    <= "01000000"; -- or B"01000000"
my_vector    <= X"40";      -- 0100 0000
my_vector    <= O"100"     -- (0)01 000 000
```

Extensions (VHDL-2008):
 7X'0F" - 7Bit - "0001111"
 7UX'F" - Unsigned - "0001111"
 7SX'F" - Signed - "1111111"
 7SX'7" - Signed - "0000111"
 my_vector <= 8D'64";

Named Association:

```
my_vector <= ( 0=>'0', 7=>'0', 6=>'0', 4=>'0', 3=>'0', 5=>'0', 2=>'0', 1=>'1' );
my_vector <= ( 1=>'1', 0 | 2 | 3 | 4 | 5 | 6 | 7 => '0' );
my_vector <= ( 0=>'0', 1=>'1', 2 TO 7 => '0' );
my_vector <= ( 1=>'1', OTHERS => '0' );
```

position => value

New in VHDL 2008 (Bitstring in named (mixed??) association):

```
my_vector <= ("0100", OTHERS => '0');
```

0100 at left side

18/03/2019

Universität Rostock, IEF, Institut GS

64

Composite Types (Records)

```
TYPE alu_instr IS (add, sub, adc, sbb);
TYPE address IS RANGE 0 TO 127;
```

```
TYPE instruction
RECORD
opcode: alu_instr;
op1, op2: address;
END RECORD;
```

Elements of different types

```
SIGNAL code_bus: instruction;
SIGNAL alu_control: alu_instr;
SIGNAL src, dst: address;
```

```
alu_control <= code_bus.opcode;
src <= code_bus.op1;
dst <= code_bus.op2;
```

record identifier

element identifier

Subtypes

```
TYPE type1 IS RANGE 1 TO 12;
TYPE type2 IS RANGE 1 TO 12;
```

```
SIGNAL sig1: type1;
SIGNAL sig2, sig3: type2;
```

```
sig1 <= sig3; -- ERROR !
sig2 <= sig3; -- OK.
```

Signals must be of the same type at both sides

Subtypes are compatible with each other

```
SUBTYPE reg_adr IS integer RANGE 0 TO 127;
SUBTYPE word IS bit_vector ( 15 DOWNT0 0);
SUBTYPE ascii IS character; -- synonym
```

Predefined subtypes in VHDL:

```
SUBTYPE positive IS RANGE 1 TO integer'high;
SUBTYPE natural IS integer RANGE 0 TO integer'high;
```

Testbench

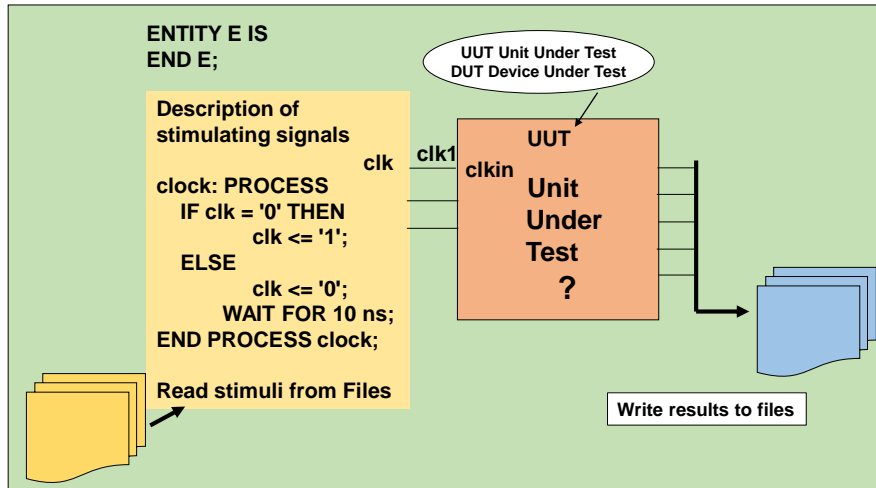

18/03/2019

Universität Rostock, IEF, Institut GS

67

File Types and Files

It is possible to store values in files.
Files contain values of one type only.

VHDL-87 uses
different syntax!
-> incompatible

Declaration of a file type:
TYPE file_type IS FILE OF element_type;

Declaration of a file using file_type:
FILE file_name : file_type IS "name_in_env";

Identifier in VHDL

Real Name in the
Computer File System

recommended one association only

Representation of data
host (OS) and simulator dependent
Portability -> 0

FILE file_name : file_type FILE_OPEN_MODE IS name_in_env;

read_mode, write_mode, append_mode

default

18/03/2019

Universität Rostock, IEF, Institut GS

68

Using Files (VHDL 93 +)

Read:

```
TYPE file_type IS FILE OF element_type;
FILE file_name : file_type READ_MODE IS myfile;
```

```
PROCEDURE read (FILE myfile: file_type; value: OUT element_type);
```

```
FUNCTION endfile (FILE myfile: file_type) RETURN boolean;
```

Usage example: if not endfile(myfile) then function with additional
 read(myfile, mysignal); parameter "length" available
 end if;

Write:

```
TYPE file_type IS FILE OF element_type;
FILE file_name : file_type WRITE_MODE IS myfile;
```

```
PROCEDURE write (FILE myfile: file_type; value: IN element_type);
```

Usage example: write(myfile, mysignal)

For advanced usage of files:
Procedures : "file_open" , "file_close" , Type: "file_open_status"

TEXTIO

Way out of the host and simulator dependency of data representation in files

Textfiles (type "text") contain elements of type string.
Elements (strings) are accessed by a pointer line.

input, output predefined for
 simulators command-line
 (keyboard, display)

```
FILE input : text OPEN read_mode IS "std_input";
FILE output : text OPEN write_mode IS "std_output";
```

Use your (VHDL-) name here

Use your (Filesystem-) name here

```
PROCEDURE read (L: INOUT line; value OUT bit_vector );
PROCEDURE read (L: INOUT line; value OUT bit_vector, good: OUT boolean);
```

```
PROCEDURE write (L: INOUT line; value IN bit_vector ;
justified: IN side:=right; field: IN width := 0 . );
```

bit, bit_vector, boolean, character,
 integer, real, string, time

Procedures for
 different types available

right " 001"
 left "001 "

Minimal number
 of characters
 (spaces included)

additional:
 "unit" for time, "digits" for real

use IMAGE and VALUE attributes
 for user defined types

```
write (line, state_variable_type'image(state_variable));
```

TEXTIO - Example from Lab "cnt9999"

use std.textio.all; -- At top of VHDL description

Generic (Short_time: integer range 0 to 25000 := 25000;
Long_time: integer range 0 to 1000 := 1000); -- Parameter in entity declaration

file integer_file: text open write_mode is "integer_file.txt"; --Declaration in architecture

```
Writetofile: process(dig_array) - - Process to store value if a digit changes its value
Variable simtime: time;
Variable integer_line: line;
begin
    if reset_int'last_value = '1' then --Start time with falling edge of reset
        simtime := (25000/Short_time * 1000/Long_time) * reset_int'last_active; --Correction of acceleration
        else simtime := now; --Before reset ends use actual time
        end if;
    write(integer_line, simtime, justified => right, field=> 20, unit => ms);
    write(integer_line, string(": "));
    for i in 3 downto 1 loop
        write(integer_line, dig_array(i));
    - -We can use the 8-bit character set: here Spanish upside down exclamation mark
        write(integer_line, string(" " & character'val(161) & " "));
        end loop;
    write(integer_line, dig_array(0));
    writeline(integer_file, integer_line);
end process Writetofile;
```

Result in "integer_file.txt"

```
0 ms: 0 | 0 | 0 | 0
0 ms: 9 | 9 | 9 | 5
1000 ms: 9 | 9 | 9 | 6
2000 ms: 9 | 9 | 9 | 7
```

TEXTIO - Example from Lab "vga"

We want to see the vga-output as an image during simulation.

Solution: Generate a Bitmap File

Simple structure: Header + n x 3 Bytes (blue,green,red)

Problem:

Long simulation times

16.7 ms simulation time per picture

Modelsim_64Bit Windows10,

i7-4790 CPU @ 3.60GHz, 32 GB

188 sec -> 11.25 s / picture

(same time for project on network or local)

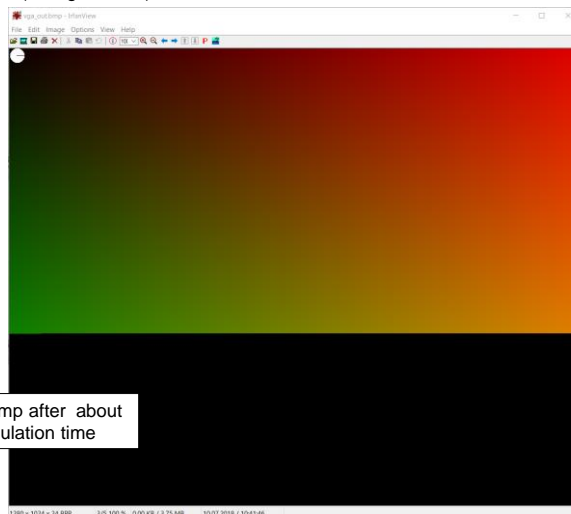

vga_out.bmp after about
10 ms simulation time

TEXTIO - Example from Lab "vga"

We want to see the vga-output as an image during simulation.
 Solution: Generate a Bitmap File
 Simple structure: Header + n x 3 Bytes (blue,green,red)

Bitmap: block

```

type bitmap_header_type is array (0 to 53) of integer;
constant bitmap_header: bitmap_header_type :=
( 16#42#, 16#4D#, --"BM"
  16#36#, 16#00#, 16#3C#, 16#00#, -- Size of BMP: 1280x1024x3+54 = 3932214 = 003C0036H
  16#00#, 16#00#, 16#00#, 16#00#,
  16#36#, 16#00#, 16#00#, 16#00#, -- Offset of pixel array to start of bitmap file (standard 54 Bytes = 36H)
  --DIB (Device Independent Bitmap) Header
  16#36#, 16#00#, 16#00#, 16#00#, -- 40 Bytes DIB header length
  16#00#, 16#05#, 16#00#, 16#00#, -- Width of bitmap 1280 = 500H
  16#00#, 16#FC#, 16#FF#, 16#FF#, -- Height of bitmap 1024 = 400H, top to bottom negative FFFF00H
  16#01#, 16#00#, -- one color plane
  16#18#, 16#00#, -- 24 bits per pixel (one byte/color blue/red/green)
  16#00#, 16#00#, 16#00#, 16#00#, -- no compression
  16#36#, 16#00#, 16#3C#, 16#00#, -- Size of raw bitmap data: 1280x1024x3 = 3932160 = 3C0000
  16#13#, 16#0B#, 16#00#, 16#00#, -- Print resolution horizontal 72 DPI (2835 pixel/metre)
  16#13#, 16#0B#, 16#00#, 16#00#, -- Print resolution vertical 72 DPI (2835 pixel/metre)
  16#00#, 16#00#, 16#00#, 16#00#, -- 0 colors in palette
  16#00#, 16#00#, 16#00#, 16#00#); -- 0 important colors

type bitmap_file_type is file of character;
file bitmap_file: bitmap_file_type open write_mode is "vga_out.bmp";
signal header_flag : boolean := true;
signal virgin: boolean := true;
    
```

18/03/2019

Universität Rostock, IEF, Institut GS

73

Files: Example from Lab "VGA"

```

begin
Write_BMP: process(VIDEOCLK)
begin
if rising_edge(VIDEOCLK) then
if VSYNC = '0' or virgin= true then
virgin <= false;
if header_flag = true then
header_flag <= false;
file_close(bitmap_file);
file_open(bitmap_file,"vga_out.bmp",write_mode);
for i in 0 to 53 loop
write(bitmap_file, character'val(bitmap_header(i)));
end loop;
end if;
end if;
if BLANK = '1' then
header_flag <= true;
--write pixels
write(bitmap_file,character'val(to_integer(unsigned(blue))));
write(bitmap_file, character'val(to_integer(unsigned(green))));
write(bitmap_file, character'val(to_integer(unsigned(red))));
end if;
end if;
end process Write_BMP;
end block Bitmap;
    
```

Here we must look into the textio library
 What types are available?
 What is their format in the files?
 Example: Integer always Bytes (32 Bit)

T'VAL(X) is the value of discrete type T at integer position X.

18/03/2019

Universität Rostock, IEF, Institut GS

74

Find Errors in VGA-Lab Design analyzing Bitmap File

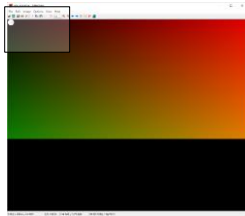

Increment of the pacman position was too late, effective in the second line for the first time.

Changed to an earlier point of time: start of vblank instead of end of vblank

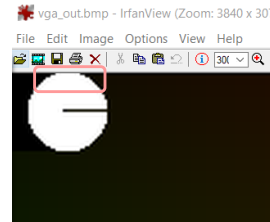
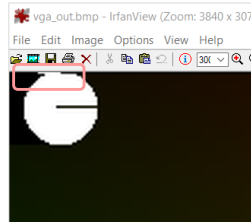
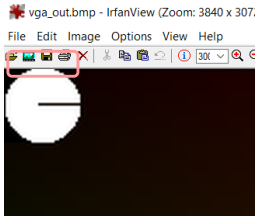

```

newballpos:
  process (vclk)
  begin
    if (vclk'event and vclk = '1') then
      vblankold <= vblank;
      if (((vblankold xor vblank) = '1') and ( vblank = '1' )) then --detect end of picture
        ....
        ball_hpos <= ball_hpos + 5;
  end process;

```

changed from '0' to '1'

Example for Synthesis Problems (Type Conversion) I

Simple Problem: Text defined as a constant with type „string“ shall be transferred as a byte or later bitwise by a serial interface. We need the characters as 8 bit vectors. Logically there is no conversion necessary because, for example Character-code for 'a' is 41h "converted" to std_logic_vector 41h. But we can't access single bits or slices from a character.

```

constant line1: string(1 to 16) := "abcdefghijklmnop";
signal index: integer range 1 to 16;
signal databyte: std_logic_vector (7 downto 0);

```

```

databyte <= CONV_STD_LOGIC_VECTOR(character'pos(line1(index)),8);

```

Worked well within Modelsim, but failed without comment in Xilinx Synthesis Tool ISE

Example for Synthesis Problems (Type Conversion) II

Solution : type T is array(CHARACTER range NUL to DEL) of STD_LOGIC_VECTOR(7 downto 0);

```
constant CHAR2STD: T :=
("0000000", "0000001", "0000010", "0000011",
"0000100", "0000101", "0000110", "0000111",
"0000100", "0000101", "0000101", "0000101",
"0000100", "0000101", "0000110", "0000111",
"0001000", "0001001", "0001001", "0001001",
"0001010", "0001011", "0001010", "0001011",
"0001000", "0001001", "0001010", "0001011",
"0001100", "0001101", "0001110", "0001111",
"0010000", "0010001", "0010001", "0010001",
"0010010", "0010011", "0010010", "0010011",
"0010100", "0010101", "0010101", "0010101",
"0010110", "0010111", "0010110", "0010111",
"0011000", "0011001", "0011001", "0011001",
"0011010", "0011011", "0011010", "0011011",
"0011100", "0011101", "0011110", "0011111",
"0100000", "0100001", "0100001", "0100001",
"0100010", "0100011", "0100010", "0100011",
"0100100", "0100101", "0100101", "0100101",
"0100110", "0100111", "0100110", "0100111",
"0101000", "0101001", "0101001", "0101001",
"0101010", "0101011", "0101010", "0101011",
"0101100", "0101101", "0101110", "0101111",
"0101000", "0101001", "0101010", "0101011",
"0101100", "0101101", "0101110", "0101111",
"0110000", "0110001", "0110001", "0110001",
"0110010", "0110011", "0110010", "0110011",
"0110100", "0110101", "0110101", "0110101",
"0110110", "0110111", "0110110", "0110111",
"0111000", "0111001", "0111001", "0111001",
"0111010", "0111011", "0111010", "0111011",
"0111100", "0111101", "0111110", "0111111");
end CHAR2STD;
```

Implementation in Synthesis ?

```
databyte <= CHAR2STD(line1(index));
```

Attributes I

Annotation of additional Information

Attributes for Types, Arrays, Signals, Entities Predefined and User-defined Attributes

Identifier'attribute_identifier

Predefined Attributes for Scalar Types

type'LEFT - Value of the leftmost position in type declaration
type'RIGHT - Value of the rightmost position in type declaration
type'LOW - Least value of the type
type'HIGH - Greatest value of the type

TYPE color IS (red, green, blue, magenta, cyan, yellow);

color'LEFT = color'LOW = red
color'RIGHT = color'HIGH = yellow

In enumeration types values
are ordered from left to right

Attributes II

TYPE address IS RANGE 0 TO 127;

**address'low = address'left = 0
address'high = address'right = 127**

TYPE address IS RANGE 127 DOWNTO 0;

**address'low = address'right = 0
address'high = address'left = 127**

type'POS(X) Position of value X in type declaration (starting left with 0)
type'VAL(P) Value at the position P in type

TYPE color IS (red, green, blue, magenta, cyan, yellow);

**color'POS(blue) = 2
color'VAL(3) = magenta**

type'SUCC(X) **type'PRED(X)** Next value (greater/smaller)
type'LEFTOF(X) **type'RIGHTOF(X)** Value at Position +-1

color'LEFTOF(green) = color'PRED(green) = red

Attributes III

type'ASCENDING TRUE if type has an ascending range

type'IMAGE(x) textual representation of the value x in type

type'VALUE(s) value in type represented by the string s

Can be used for writing
and reading of values into and
from text files

Attributes IV

Attributes of (constrained) Arrays:

array'LEFT(n)	left bound of index range in dimension n
array'RIGHT(n)	right bound of index range in dimension n
array'LOW(n)	lowest index value in dimension n
array'HIGH(n)	highest index value in dimension n

array'LENGTH(n)	number of elements in dimension n
array'RANGE(n)	range definition in dimension n
array'REVERSE_RANGE(n)	reverse range definition in dimension n

array'ASCENDING	true if range in dimension n is ascending
------------------------	---

```
SIGNAL : vec_1 IS bit_vector ( 7 DOWNTO 0);
vec_1'LEFT = vec_1'HIGH      7
vec_1'RIGHT = vec_1'LOW     0
vec_1'LENGTH                 8
vec_1'RANGE                  7 DOWNTO 0
vec_1'REVERSE_RANGE         0 TO 7
vec_1'ASCENDING              FALSE
```

Default dimension is (1)

Attributes V

Attributes of Signals:

Attribute is a new signal

signal'DELAYED(time)	Original signal delayed by time
signal'STABLE(time)	New signal of type boolean TRUE if signal hasn't changed for time, else FALSE
signal'QUIET(time)	New signal of type boolean TRUE if no assignment has been made for time, else FALSE
signal'TRANSACTION	New signal of type BIT changing its value between '0' and '1' whenever a new assignment for the original signal was made

Attribute is a value (no new signal)

signal'EVENT	TRUE when during the last simulation cycle a change of the value occurred
signal'ACTIVE	TRUE when during the last simulation cycle an assignment to the signal was made
signal'LAST_EVENT	time from the last change of signal to actual time
signal'LAST_ACTIVE	time from the last assignment to signal to actual time
signal'LAST_VALUE	value of the signal before the last event (diff. '87/'93)

signal'DRIVING	True if the containing process drives the signal
signal'DRIVING_VALUE	value contributed by the containing process

VHDL'93 only

Attributes VI

Avoid them -> Portability

User defined attributes:

(Interesting because we find "software vendor defined attributes" sometimes)

Declaration:

```
ATTRIBUTE attribute_identifier : type;
```

Assignment:

```
ATTRIBUTE attribute_identifier OF target_identifier:target_kind IS value;
```

Signals, types components
can have identical identifiers

```
ATTRIBUTE pin_number : positive;  
TYPE logic_levels IS (cmos,ttl);  
ATTRIBUTE input_kind : logic_levels;
```

```
ATTRIBUTE pin_number OF in1:SIGNAL IS 12;  
ATTRIBUTE input_kind OF in1, in3, in4 : SIGNAL IS cmos;
```

```
in1'input_kind = cmos
```

18/03/2019

Universität Rostock, IEF, Institut GS

83

Attribute FOREIGN

The attribute Foreign enables interfaces to non VHDL tools and libraries

Content is **tool dependent !!** -> **Not portable !!**

String-attribute for architectures and subroutines

Example:

```
PROCEDURE create_window (size_x, size_y: IN positive;  
                          status: OUT boolean);
```

```
ATTRIBUTE foreign OF create_window: PROCEDURE IS
```

```
"bind to open_window" &
```

```
"parameter x_size maps to size_x: IN positive" &
```

```
"parameter y_size maps to size_y: IN positive" &
```

```
"parameter state maps to status: OUT boolean";
```

```
END PROCEDURE create_window;
```

Non VHDL

It depends on the tool, what is done with the attribute string in the environment.
Architectures or Procedures are replaced by implementations in other languages
or special external hardware ...

18/03/2019

Universität Rostock, IEF, Institut GS

84

Attributes (SYNOPSYS-Example)

```

ATTRIBUTE enum_encoding
    TYPE color IS (red, yellow, black);

ATTRIBUTE enum_encoding : STRING;
ATTRIBUTE enum_encoding OF color : TYPE IS "01 10 11";
    
```

Synthesis Software (Design Compiler) reads the attributes and encodes the abstract enumeration values as binary representations. (There exist also other ways to control encoding.)

Structural Description

Component Declaration

```

COMPONENT identifier IS
    GENERIC (parameter_interface_list);
    PORT (port_interface_list);
end COMPONENT identifier;
    
```

Component Instantiation

```

inst_label: COMPONENT identifier
    GENERIC MAP (locals => actuals)
    PORT MAP (locals => actuals);
    
```

Component Specification

```

FOR inst_label : identifier USE ENTITY
    library_name.entity_name(architecture_name);
    
```

(Optional: Without specification the component with the entity_name identical to the identifier is taken from library work. The most recently analyzed (newest) architecture is used)

Direct Component Instantiation

```
entity and_gate is
  port ( a, b in bit; y out bit);
end entity and_gate;
```

```
architecture arch1 of and_gate is
begin
  y <= a and b after td;
end architecture arch1;
```

```
U112: entity work.and_gate(arch1)
  port map ( a => ext1 , b => ext2, y => ext3);
```

Instantiation_label: entity library_name.entity_name(architecture_name)
....

Not included in VHDL'87

Generics

Generics are parameters in VHDL
Generics are constants with mode "IN".
Generics are used to parametrize behaviour/structure of an entity

```
entity and_gate is
  generic (td: time:= 2 ns);
  port ( a, b in bit; y out bit);
end entity and_gate;
```

```
architecture behav of and_gate is
begin
  y <= a and b after td;
end architecture behav;
```

default value

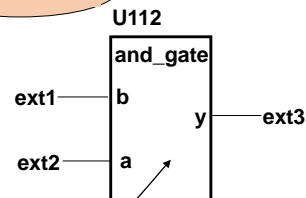

```
U112: entity work.and_gate(behav)
  generic map (td => 3 ns)
  port map ( a => ext2 , b=> ext1, y=> ext3);
```

actual value

Shift Register I

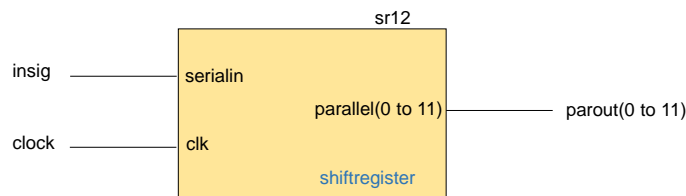
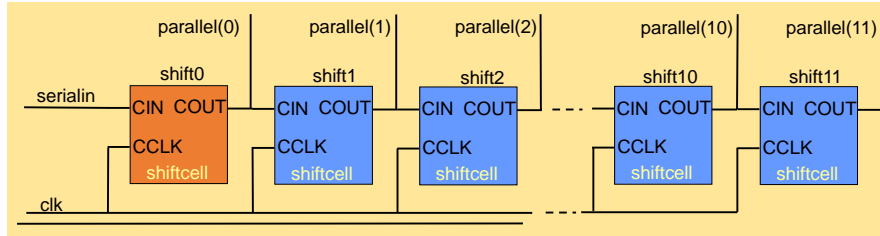

18/03/2019

Universität Rostock, IEF, Institut GS

89

Generate Statement

Description of replicated subsystems (processes or component instantiations)

Label: generation scheme **GENERATE**
concurrent statements
END GENERATE label;

FOR identifier IN discrete_range
 IF condition

VHDL-2008 IF with
 ELSIF, ELSE branches
 dto. CASE ..

```
ENTITY shiftregister IS
    PORT (clk, serialin: IN std_logic;
          parallel: BUFFER std_logic_vector( 0 TO 11));
END shiftregister;
```

```
ARCHITECTURE structure OF shiftregister IS
    COMPONENT shiftcell
        PORT (cclk; cin : IN std_logic;
              cout : OUT std_logic);
    END COMPONENT shiftcell;
```

```
shift0 : shiftcell (clk, serialin, parallel(0));
gen_shift: FOR i in 1 TO 11 GENERATE
    → shift: shiftcell PORT MAP (clk, parallel(i-1), parallel(i));
    END GENERATE gen_shift;
END ARCHITECTURE structure;
```

Will become:
 shift1, shift2 ...

18/03/2019

Universität Rostock, IEF, Institut GS

90

Shift Register II

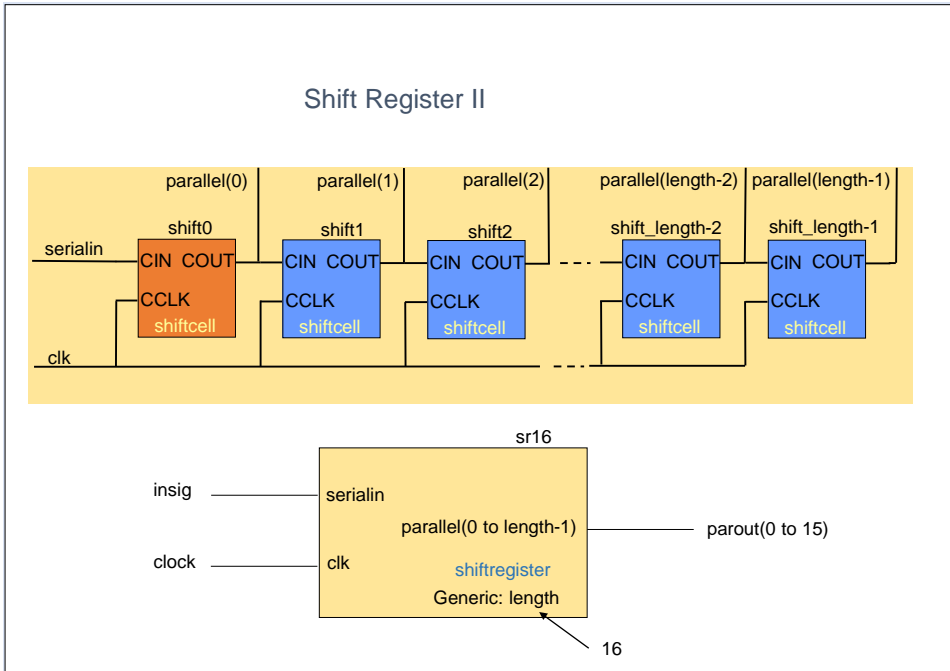

18/03/2019

Universität Rostock, IEF, Institut GS

91

Generate and Generic

```

ENTITY shiftregister IS
    GENERIC (length : positive := 12);
    PORT (clk, serialin: IN std_logic;
          parallel: BUFFER std_logic_vector( 0 TO length-1));
END shiftregister;

ARCHITECTURE structure OF shiftregister IS
    COMPONENT shiftcell
        PORT (cclk; cin : IN std_logic;
              cout : OUT std_logic);
    END COMPONENT shiftcell;

    shift0 : shiftcell (clk, serialin, parallel(0));
    gen_shift: FOR i in 1 TO length-1 GENERATE
        shift: shiftcell PORT MAP (clk, parallel(i-1), parallel(i));
    END GENERATE gen_shift;
END ARCHITECTURE structure;
    
```

```

sr16: shiftregister
    GENERIC MAP (length=>16)
    PORT MAP (clock, insig, parout);
    
```

18/03/2019

Universität Rostock, IEF, Institut GS

92

Generate - Conditional Code

Exclude code from synthesis

```
if Simulation = '1' generate
  Code
end generate;
```

Better than metacommments (because portable)
Disadvantage: Parameter Simulation must be handled

```
-- synthesis translate_off
Code
--synthesis translate_on
```

metacommments

Write Code depending on the value of static parameter_x

```
if Parameter_x = '1' generate
  Code 1
end generate;

if Parameter_x = '0' generate
  Code 2
end generate;
```

VHDL-2008 IF with
ELSIF, ELSE branches
dto. CASE ..

Resolution Function

```
TYPE bit4v IS ('X', '0', '1', 'Z');
TYPE bit4v_vec IS ARRAY (integer RANGE <> OF bit4v);
```

```
FUNCTION wired_or (input: bit4v_vec) RETURN bit4v IS
```

```
  VARIABLE result : bit4v := '1';
BEGIN
  FOR i IN input'RANGE LOOP
    IF input(i) = '0' then
      result := '0'; EXIT ;
    ELSIF input(i) = 'X' THEN
      result := 'X'; NEXT;
    END IF;
  END LOOP;
  RETURN result;
END FUNCTION wired_or;
```

```
SUBTYPE bit4v_res IS wired_or bit4v;
```

```
SIGNAL sig27: wired_or bit4v;
SIGNAL sig28: bit4v_res;
```

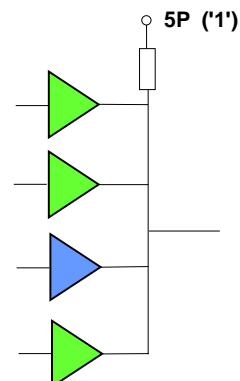

Alias

By help of an alias we can declare a new name for an object

```
SIGNAL ProgRegister: std_logic_vector(7 DOWNT0 0);  
ALIAS EnableInterrupt:std_logic IS ProgRegister(7);  
ALIAS Bitrate:std_logic_vector(4 downto 0) IS ProgRegister(6 DOWNT0 4);  
ALIAS Prescaler:std_logic_vector(3 downto 0) IS ProgRegister(3 DOWNT0 0);
```

VHDL allows the simple alias without a subtype (red in the Examples),
but some software (SYNOPTSYS) needs the subtype declaration

Package

Packages contain declarations and subroutine implementations

```
PACKAGE mypack IS  
  
    CONSTANT    frame_length : POSITIVE := 1500;  
    TYPE        instruction IS (add , sub, adc, sbb );  
    SUBTYPE     word IS bit_vector (31 DOWNT0 0);  
  
    FUNCTION ">" (a,b : in WORD) RETURN boolean;  
    PROCEDURE add (term1, term2: IN bit_vector;  
                  sum: OUT bit_vector;  
                  carry: OUT bit)  
  
END PACKAGE mypack;
```

Package Body

Necessary only if the package contains subprograms

Operator Overloading

Repeated from Declaration

```
PACKAGE BODY mypack IS
  FUNCTION ">" (a,b : in WORD) RETURN boolean IS
  VARIABLE result: BOOLEAN := FALSE;
  BEGIN
    FOR i IN 31 DOWNTO 0 LOOP
      IF a(i) = '1' AND b(i) = '0' THEN result := TRUE; EXIT;
      IF a(i) = '0' AND b(1) = '1' THEN result := FALSE; EXIT;
      END IF;
    END LOOP;
    RETURN result;
  END FUNCTION ">";
  .... Bodies of other Functions and Procedures
END PACKAGE BODY mypack;
```

Analyze package declaration before package body !

Configurations

Specify which description will be used actually

If an entity "counter" with one architecture "simple" exists in the library WORK the following configurations are equivalent for an architecture "testbench" in the entity "E"

```
CONFIGURATION count_test2 OF E IS
  FOR testbench
  FOR UUT:counter USE entity WORK.counter(simple);
  END FOR;
  END FOR;
END count_test2;
```

ALL

Without a given architecture use the newest architecture

```
CONFIGURATION count_test4 OF E IS
  FOR testbench
  END FOR;
END count_test4;
```

The configuration can be part of a description file or a separate file.

Equivalent Configurations

If an entity "counter" with one architecture "simple" exists in the library WORK the following configurations are equivalent for an architecture "testbench" in the entity "E"

```
CONFIGURATION count_test1 OF e IS
  FOR testbench
    FOR ALL:counter USE entity WORK.counter(simple);
  END FOR;
END FOR; END count_test1;
```

```
CONFIGURATION count_test2 OF e IS
  FOR testbench
    FOR UUT:counter USE entity WORK.counter(simple);
  END FOR;
END FOR; END count_test2;
```

```
CONFIGURATION count_test3 OF e IS
  FOR testbench
    FOR UUT:counter USE entity WORK.counter;
  END FOR;
END FOR; END count_test3;
```

```
CONFIGURATION count_test4 OF e IS
  FOR testbench
  END FOR; END count_test4;
```

18/03/2019

Universität Rostock, IEF, Institut GS

99

Libraries

```
LIBRARY library_identifier;
```

WORK and STD are predefined.
 WORK users working library
 STD contains Packages STANDARD and TEXTIO

Defined in
Tool Setup

Objects can be located by long names like
 SIGNAL a: IEEE.std_logic_1164.std_logic;



```
LIBRARY IEEE;
USE IEEE.std_logic_1164.all

Signal a: std_logic;
```

```
LIBRARY mylib;
USE mylib.pack1;           -- pack1.objectname
USE mylib.pack1.sreg;     -- sreg from pack1 is visible directly
USE mylib.pack1.ALL;     -- all objects in pack1 are visible
```

18/03/2019

Universität Rostock, IEF, Institut GS

100

IEEE1164

TYPE std_ulogic -> std_logic (is a **resolved type**)

'U'	uninitialized	
'X'	forced unknown	forced : 0 ... n x 100 Ohm
'0'	forced 0	
'1'	forced 1	
'Z'	high impedance	high impedance : n x MOhm
'W'	weak unknown	
'L'	weak 0	weak : n x KOhm
'H'	weak 1	
'-'	don't care	

Library includes type declarations for std_logic and std_logic_vector and functions (overloading operators like AND, OR)

18/03/2019

Universität Rostock, IEF, Institut GS

101

IEEE1164

Example: Exact function for rising clock edge

A rising edge in std_logic may be: '0' to '1', '0' to 'H', 'L' to '1' or 'L' to 'H'

```
SUBTYPE X01 IS resolved std_ulogic RANGE 'X' TO '1'; -- ('X','0','1')
FUNCTION To_X01(s : std_ulogic) RETURN X01;
FUNCTION rising_edge(SIGNAL s : std_ulogic) RETURN BOOLEAN;
```

```
FUNCTION rising_edge(SIGNAL s : std_ulogic) RETURN BOOLEAN IS
BEGIN
RETURN(s'EVENT AND (To_X01(s) = '1') AND (To_X01(s'LAST_VALUE) = '0'));
END;
```

↑
Event on s
detected

↑
Value is '1' or 'H' now

↑
Value was '0' or 'L' before

Compare with often used: clk'event and clk = '1'
Includes 'Z','X','U' to '1', but does not include 'L' to 'H' ..., when std_logic is used

18/03/2019

Universität Rostock, IEF, Institut GS

102

Operator Overloading

Operators must match the types of input and output signals

No problem for predefined types:

```
Outbit <= Inbit1 AND Inbit2;
```

But there can exist other types:

```
Out_IEEE_bit <= In_IEEE_bit1 AND In_IEEE_bit2;  
OUT_my_bit <= IN_my_bit1 AND In_my_bit1;
```

Compiler searches for an operator declaration for the given types.
Operators are declared as functions.

IEEE1164 Operator Overloading

Example: AND-function

```
TYPE stdlogic_table IS ARRAY(std_ulogic, std_ulogic) OF std_ulogic;
```

```
FUNCTION "and" (l : std_ulogic; r : std_ulogic) RETURN UX01 IS  
BEGIN  
RETURN(and_table(l, r));  
END "and";
```

```
CONSTANT and_table : stdlogic_table := (
```

```
-- | U X 0 1 Z W L H - | |  
--  
( 'U', 'U', '0', 'U', 'U', 'U', '0', 'U', 'U' ), -- | U |  
( 'U', 'X', '0', 'X', 'X', 'X', '0', 'X', 'X' ), -- | X |  
( '0', '0', '0', '0', '0', '0', '0', '0', '0' ), -- | 0 |  
( 'U', 'X', '0', '1', 'X', 'X', '0', '1', 'X' ), -- | 1 |  
( 'U', 'X', '0', 'X', 'X', 'X', '0', 'X', 'X' ), -- | Z |  
( 'U', 'X', '0', 'X', 'X', 'X', '0', 'X', 'X' ), -- | W |  
( '0', '0', '0', '0', '0', '0', '0', '0', '0' ), -- | L |  
( 'U', 'X', '0', '1', 'X', 'X', '0', '1', 'X' ), -- | H |  
( 'U', 'X', '0', 'X', 'X', 'X', '0', 'X', 'X' ) -- | - |
```

```
FUNCTION "and"(l : std_ulogic; r : std_ulogic) RETURN UX01 IS  
BEGIN  
RETURN(and_table(l, r));  
END "and";
```

Qualified Expressions

Sometimes the search for an Operator returns ambiguous results.

Example:

```
Y <= my_function ('0', x);
```

If `my_function` is declared for the type of `y` as the result, `x` as second operand and for the types `BIT` and `CHARACTER` of the first operand the operator cannot be selected.

Qualified Expression adds the type of the object:

```
Y <= my function ( Bit ('0'),x);
```

Use it, when something may be ambiguous. Mostly when you analyzed (compile) the VHDL-description and got an error.

Package std_logic_arith

```
TYPE unsigned IS ARRAY (natural RANGE <>) OF std_logic;  
TYPE signed IS ARRAY (natural RANGE <>) OF std_logic;
```

```
signed("0101") -- represents +5  
signed("1011") -- represents -5
```

```
SIGNAL S_SIG: signed (5 downto 0); -- bit 5 is the sign  
SIGNAL S_SIG: signed (0 to 5); -- bit 0 is the sign
```

```
conv_signed(signed("110"), 8) gives "11111110" as result
```

```
FUNCTION conv_std_logic_vector (ARG: unsigned; SIZE: integer) RETURN std_logic_vector;
```

```
FUNCTION "+" (L: unsigned; R: unsigned) RETURN unsigned;  
FUNCTION "+" (L: signed; R: signed) RETURN signed;  
FUNCTION "+" (L: unsigned; R: signed) RETURN signed;  
FUNCTION "+" (L: signed; R: unsigned) RETURN signed;  
FUNCTION "+" (L: unsigned; R: integer) RETURN unsigned;  
FUNCTION "+" (L: integer; R: unsigned) RETURN unsigned;  
FUNCTION "+" (L: unsigned; R: integer) RETURN std_logic_vector;
```

Package numeric_std

```
TYPE unsigned IS ARRAY (natural RANGE <>) OF std_logic;
TYPE signed   IS ARRAY (natural RANGE <>) OF std_logic;
```

```
signed("0101") -- represents +5
signed("1011") -- represents -5
```

```
SIGNAL S_SIG: signed (5 downto 0); -- bit 5 is the sign
SIGNAL S_SIG: signed (0 to 5);    -- bit 0 is the sign
```

```
to_signed(signed("110"), 8) gives "1111110" as result
```

```
std_logic_vector (ARG: unsigned) RETURN std_logic_vector;
```

```
FUNCTION "+" (L: unsigned; R: unsigned) RETURN unsigned;
FUNCTION "+" (L: signed;   R: signed)   RETURN signed;
FUNCTION "+" (L: unsigned; R: natural)   RETURN unsigned;
FUNCTION "+" (L: natural;   R: unsigned) RETURN unsigned;
FUNCTION "+" (L: signed;   R: integer)   RETURN signed;
FUNCTION "+" (L: integer;   R: signed)   RETURN signed;
```

18/03/2019

Universität Rostock, IEF, Institut GS

107

numeric_std vs. std_logic_arith

	numeric_std	std_logic_arith
Type Conversions		
std_logic_vector -> unsigned	unsigned(arg)	unsigned(arg)
std_logic_vector -> signed	signed(arg)	signed(arg)
unsigned/signed-> std_logic_vector	std_logic_vector(arg)	std_logic_vector(arg)
integer -> unsigned	to_unsigned(arg,size)	conv_unsigned(arg,size)
integer -> signed	to_signed(arg,size)	conv_signed(arg,size)
unsigned/signed -> integer	to_integer(arg)	conv_integer(arg)
integer -> std_logic_vector	std_logic_vector(to_unsigned(arg),size)	conv_std_logic_vector(arg,size)
unsigned + unsigned -> std_logic_vector	std_logic_vector(arg1 + arg2)	arg1 + arg2
signed + signed -> std_logic_vector	std_logic_vector(arg1 + arg2)	arg1 + arg2
Resize		
unsigned	resize(arg,size)	conv_unsigned(arg,size)
signed	resize(arg,size)	conv_signed(arg,size)

18/03/2019

Universität Rostock, IEF, Institut GS

108

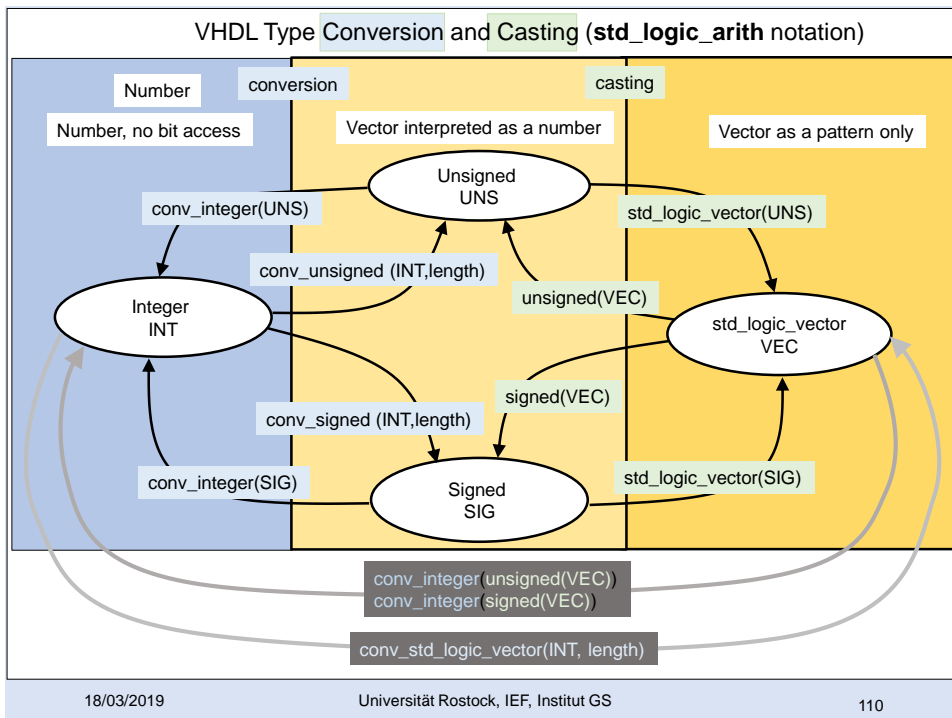
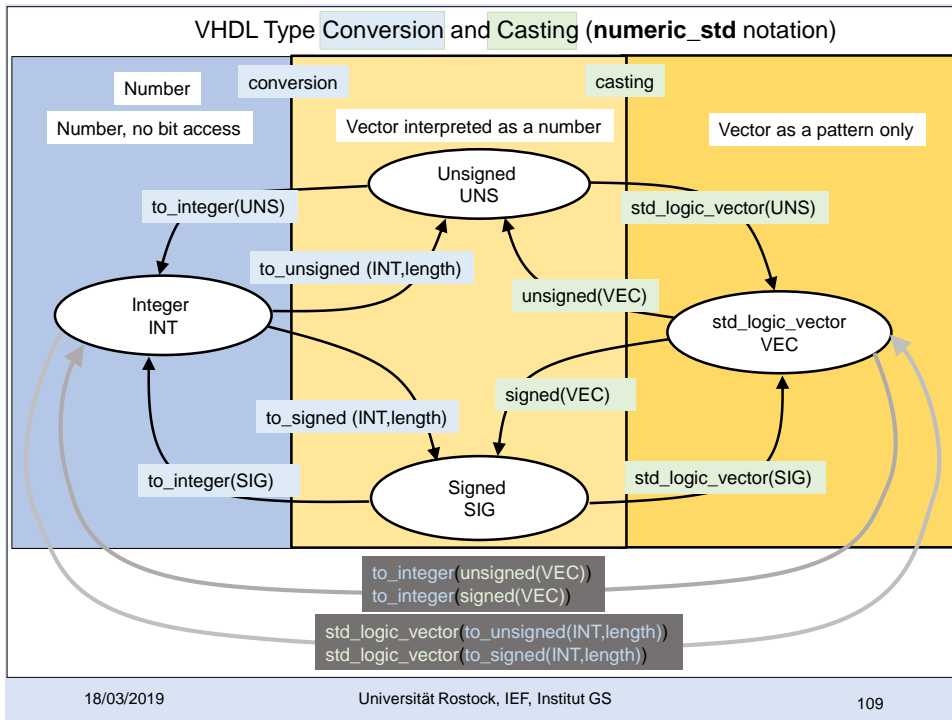

State Machines: Moore and Mealy

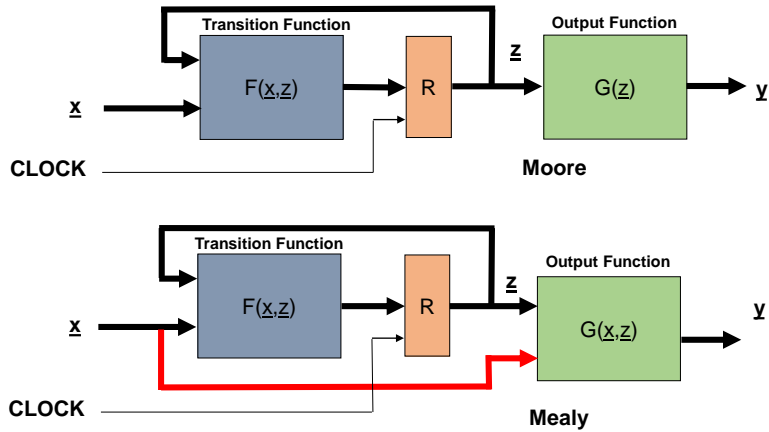

18/03/2019

Universität Rostock, IEF, Institut GS

111

State Machines: Moore 3 Processes

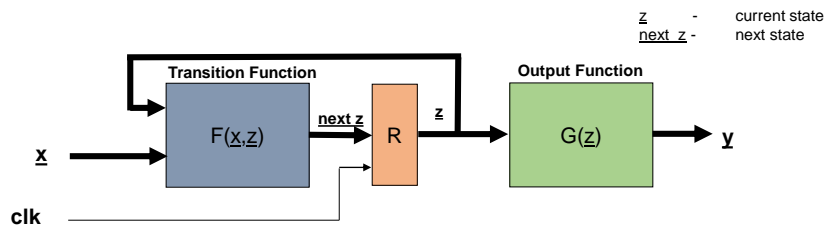

1st process (combinatorial)

```
process (z,x)
begin
case z is
when S1 => if x = x1 then next_z <= S2;
end if;
...
end case;
end process
```

2nd process (clocked)

```
process (clk)
begin
if rising_edge(z) then
z <= next_z;
end if;
end process
```

3rd process (combinatorial)

```
y <= "010" when z=S1 else
"100" when z=S2 else
"001";
```

Mealy includes input x here

Inside declarational part of architecture:

```
type z_type is (S1,S2,S3);
signal z, next_z : z_type;
```

18/03/2019

Universität Rostock, IEF, Institut GS

112

State Machines: Moore Single Process

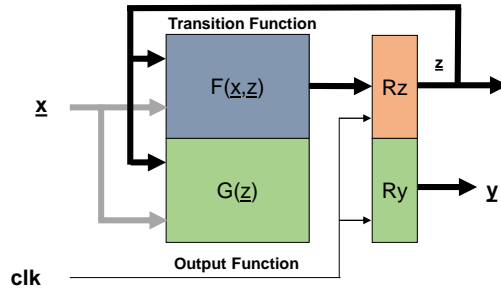

Single process (clocked)

```

process (clk)
begin
  if rising_edge(clk) then
    case z is
      when S1 => if x = x1 then z <= S2;
                    y <= "010";
            end if;
    ...
    end case;
  end if;
end process;

```

y is registered

State Machine: Implicit

Process runs from WAIT to WAIT and restarts from the top (like a loop)
There is no explicit declaration of a state signal

```

process
begin
  y <= "000";
  wait until rising_edge(clk);
  y <= "101";
  wait until rising_edge(clk);
  if x = x1 then y <= "100";
  elsif x = x2 then y <= "010";
  end if;
  wait until rising_edge(clk);
  y <= "100";
  wait until rising_edge(clk);
  ...
end process;

```

Do not use a sensitivity list for processes containing WAIT-statements!

Synthesis?

Not all synthesis programs may support implicit state machine descriptions

Synchronous and Asynchronous Reset

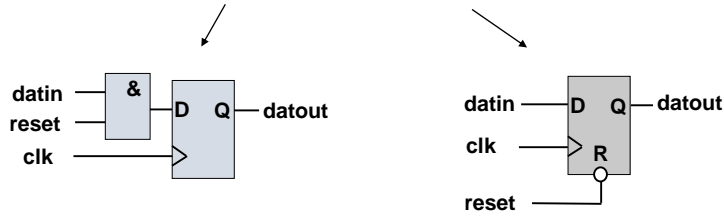

```

sr: PROCESS
  WAIT UNTIL (clk'event and clk='1');
  IF reset = '0' THEN datout <= '0';
  ELSE datout <= datin;
  END IF;
END PROCESS sr;

```

```

ar: PROCESS (clk , reset)
  IF reset = '0' THEN datout <= '0';
  ELSIF (clk'event and clk='1') THEN
    datout <= datin;
  END IF;
END PROCESS ar;

```

Example: Debouncing

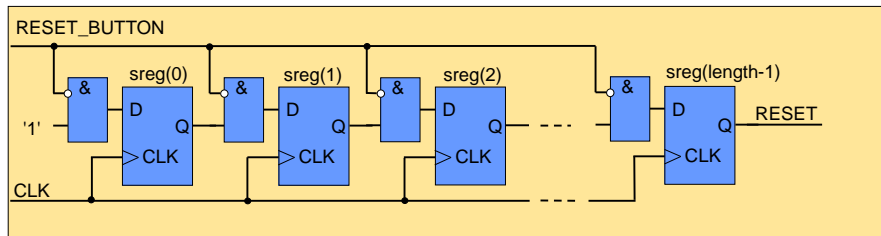
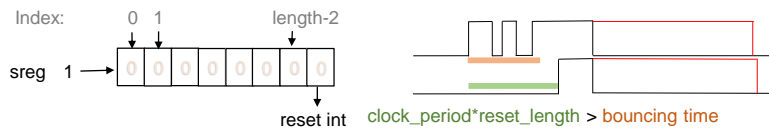

```

rstgen: Process (CLK)
begin
  if rising_edge(CLK) then
    if RESET_BUTTON = '1' then sreg <= (others => '0');
    else sreg <= '1' & sreg(0 to sreg'length-2);
    end if;
  end process rstgen;

```

Only pulses at sample moment initiate and prolong RESET output

```

RESET <= not sreg(sreg'length-1);

```

Example: Debouncing

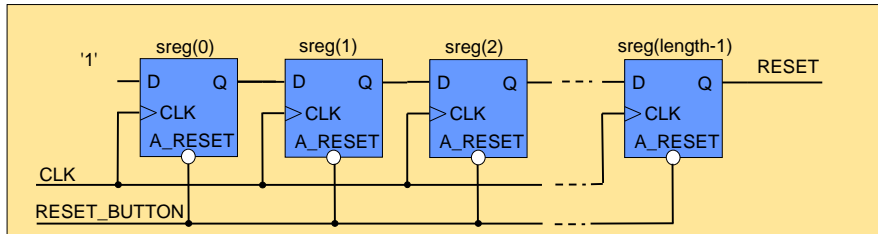

```

rstgen:  Process (CLK, RESET_BUTTON)
begin
  if RESET_BUTTON = '1' then sreg <= (others => '0');
  elsif rising_edge(CLK) then else sreg <= '1' & sreg(0 to sreg'length-2);
  end if;
end process rstgen;

```

```
RESET <= not sreg(sreg'length-1);
```

Very short pulses initiate
and prolong RESET output

Synthesis: Memory Insertion (Latch, Register)

In all processes (including clocked processes):

Be sure that all variables get a value assigned whenever the process is executed!

Otherwise in clocked processes registers (flip-flops), in combinatorial processes latches for the variables inserted.

In combinatorial processes:

Assign a value to any output of the process in all branches (if, case) when the process is executed (see sensitivity list)!

```
if inp = '1' then outp <= '0';
end if;
```

Says: When inp = '0' hold the old value → Latch insertion

Look for warnings from the synthesis program indicating latch insertion and check your code! If your intention was to make a synchronous design with edge triggered flip-flops there should not occur any Latch insertion.

Simulation: Testbench for Logic Simulation

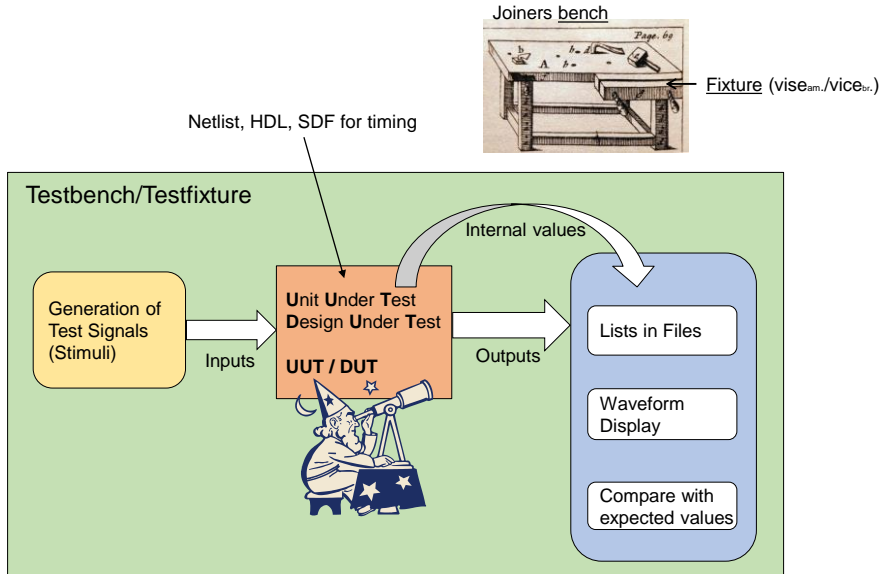

18/03/2019

Universität Rostock, IEF, Institut GS

119

Simulation: Depth of Simulation Models and Circuit Complexity

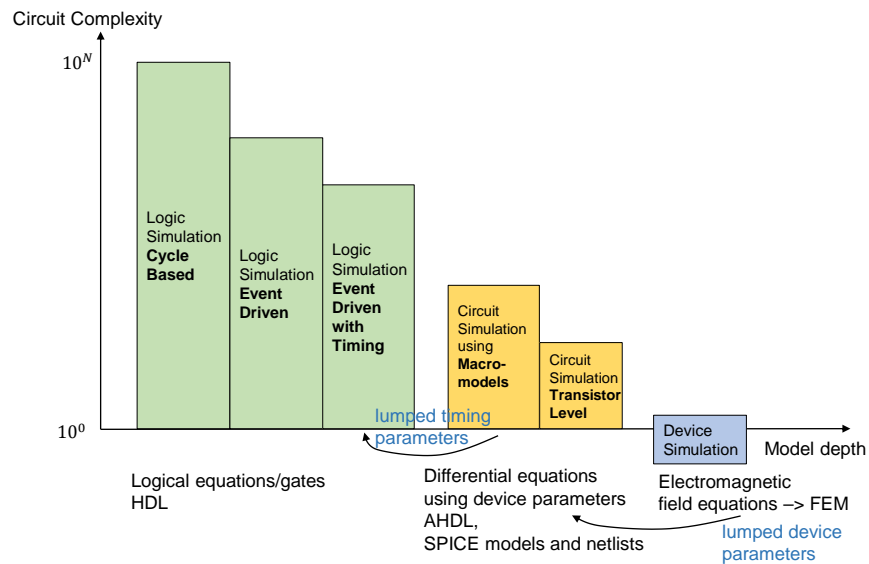

18/03/2019

Universität Rostock, IEF, Institut GS

120

Simulation as Part of the Design Process

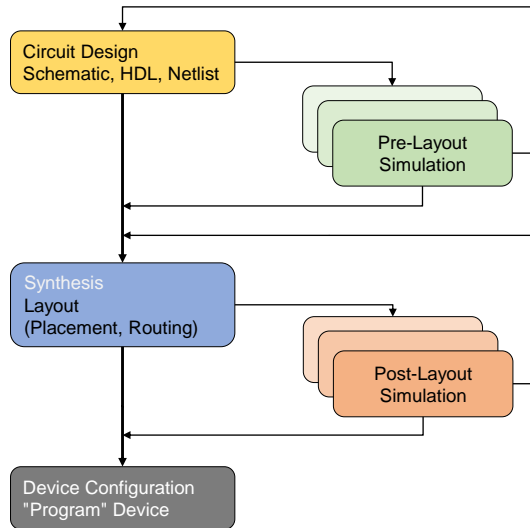

18/03/2019

Universität Rostock, IEF, Institut GS

121

Simulation

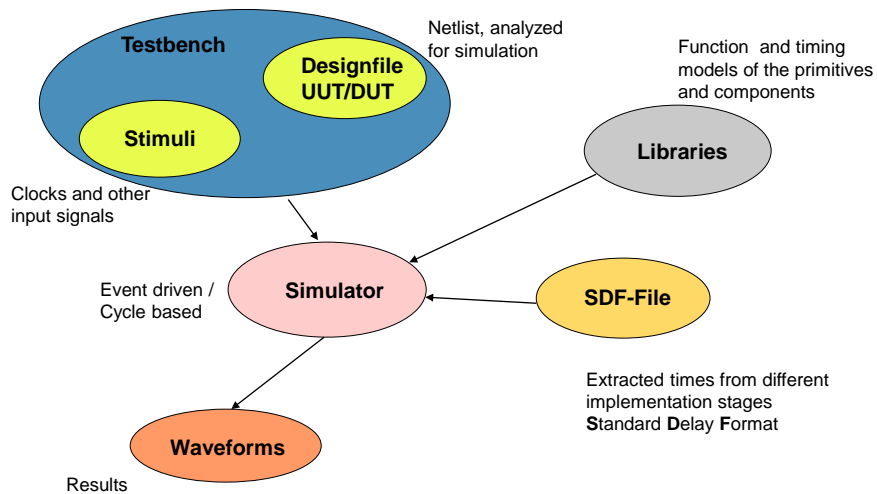

18/03/2019

Universität Rostock, IEF, Institut GS

122

Simulation Libraries (Example: Xilinx)

Functional Simulation (VHDL and Gate Level Netlist)

```
Library UNISIM;  
use UNISIM.all  
use UNISIM.VCOMPONENTS.ALL
```

```
Library XilinxCoreLib;
```

Timing Simulation

VITAL : VHDL Initiative Towards ASIC-Libraries (IEEE 1076.4)

```
Library SIMPRIM;  
use SIMPRIM.VCOMPONENTS.ALL;  
use SIMPRIM.VPACKAGE.ALL;
```

Cores are implemented as gates ...

!! Libraries have to be compiled by the actual version of imulator for the actual technology !! (Example: Modelsim 6.0a -> XILINX 7.1)
Setup files must point to the appropriate directory !

18/03/2019

Universität Rostock, IEF, Institut GS

123

Event Driven and Cycle Based Simulation

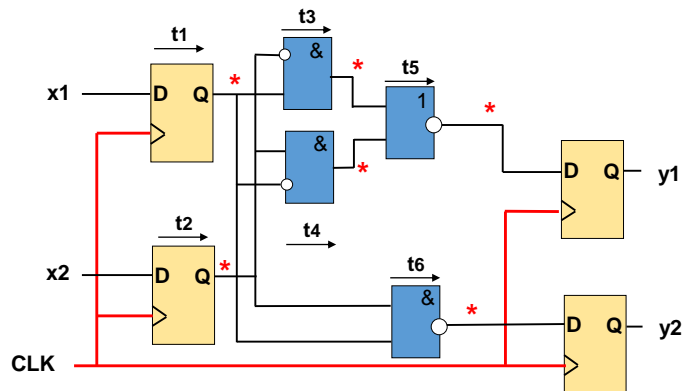

Event Driven: Whenever a delay time runs out a new simulation cycle is started
We can see what and when something happens at the * points.
Cycle Based: Only once per cycle the result is calculated

18/03/2019

Universität Rostock, IEF, Institut GS

124

Testbench and Backannotation

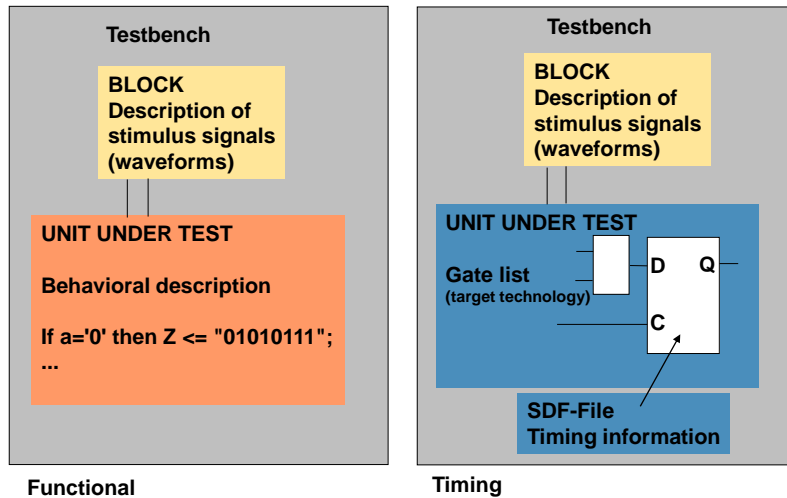

18/03/2019

Universität Rostock, IEF, Institut GS

125

Delay Calculation

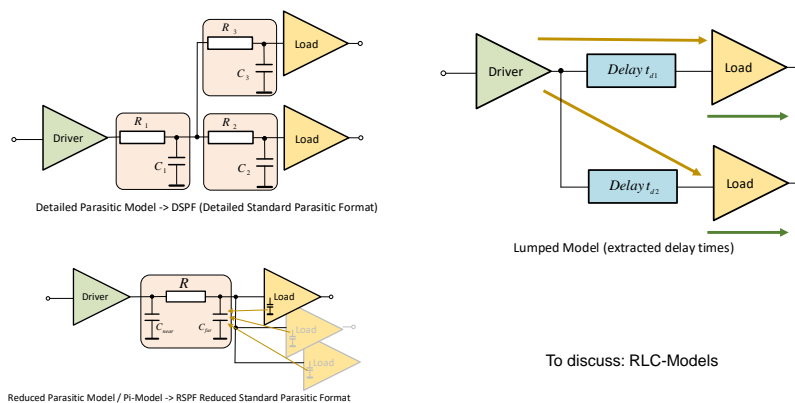

18/03/2019

Universität Rostock, IEF, Institut GS

126

Backannotation (Timing)

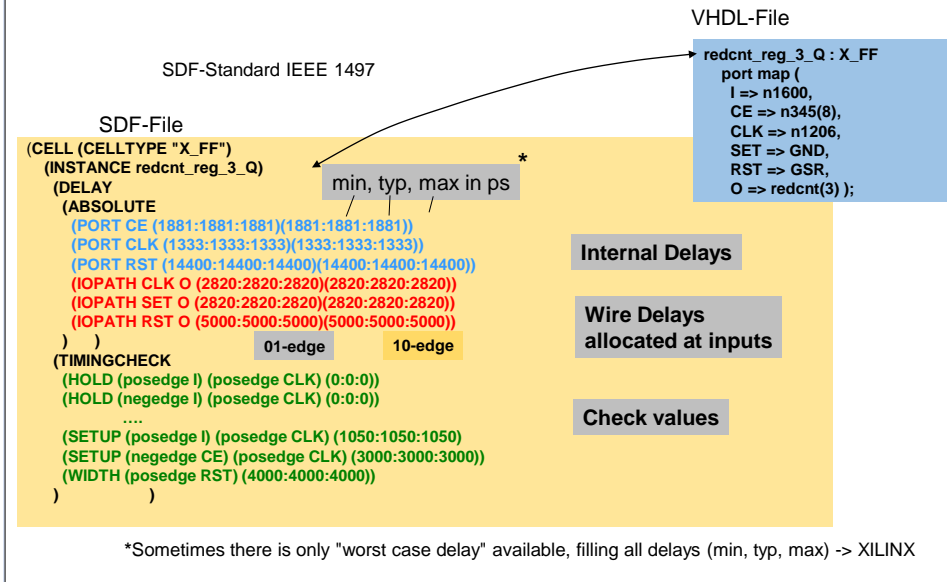

18/03/2019

Universität Rostock, IEF, Institut GS

127

Configurations for pre- and post-layout simulation

Configuration for the functional simulation using **behavioral VHDL-model**:

```

CONFIGURATION cfg_design1_tb_behavior OF e IS
FOR testbench
FOR UUT: design1 USE entity WORK.design1(behavior);
END FOR;
END FOR;
END cfg_design1_tb_behavior;
    
```

Designers architecture name

Configuration for the timing simulation using the placed and routed structure:

```

CONFIGURATION cfg_design1_tb_structure OF e IS
FOR testbench
FOR UUT: design1 USE entity WORK.design1(structure);
END FOR;
END FOR;
END cfg_design1_tb_structure;
    
```

Design Tools architecture name for post-layout VHDL description

18/03/2019

Universität Rostock, IEF, Institut GS

128

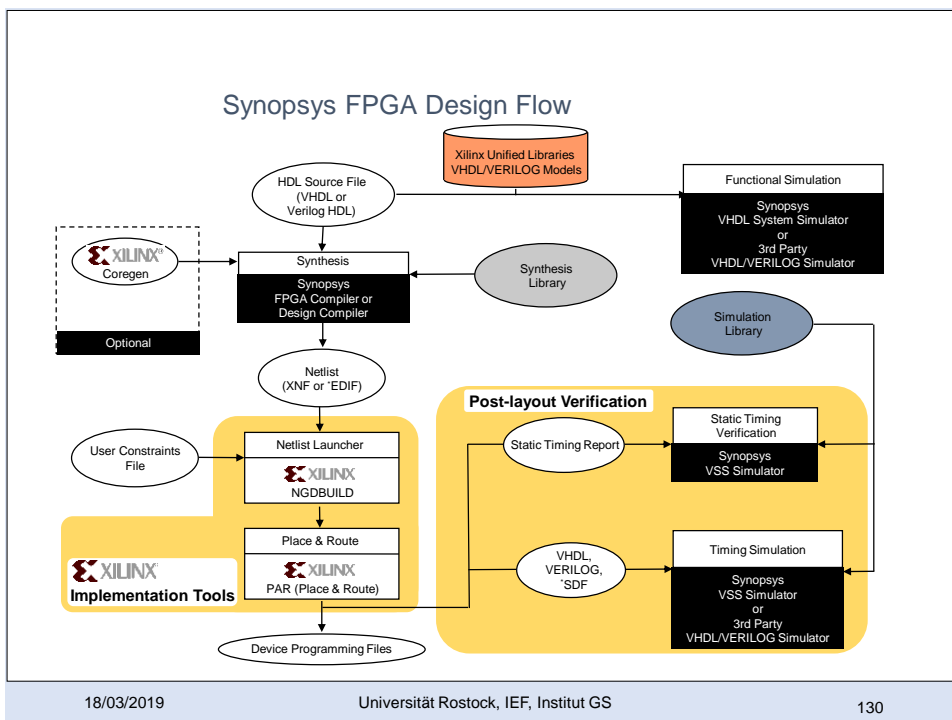
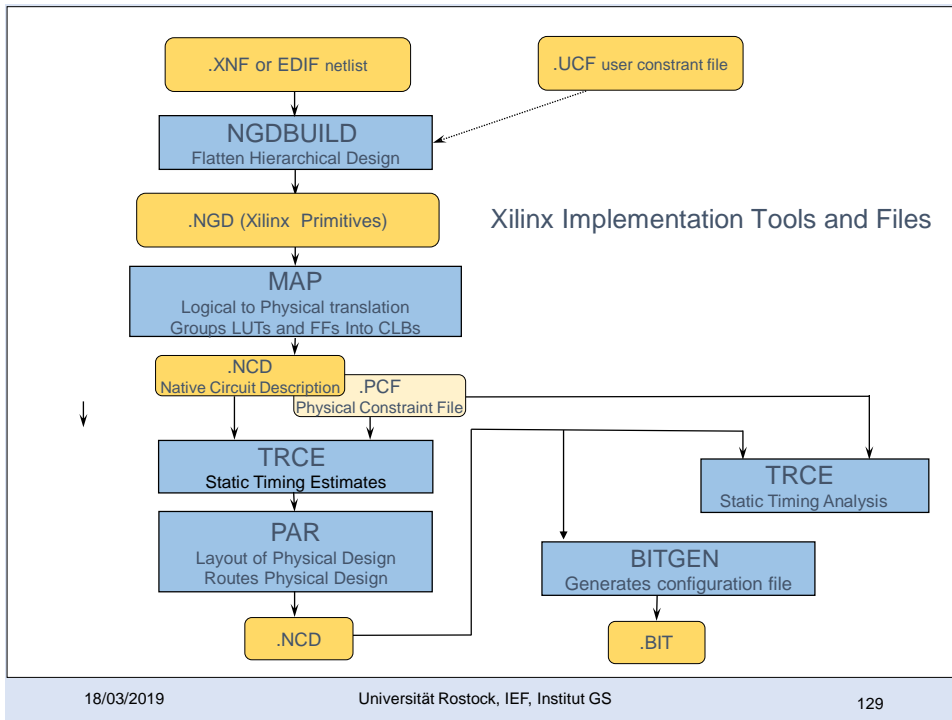

Standard Cells vs. FPGA

Standard Cells

Floorplanning

Logic rows, modules
Pading
Power rings and stripes

Placement

Generation of clock nets (trees)
Routing clock, logic

Files for mask layout

FPGA

All cell locations are ready
Mapping

Power nets are ready
Clock nets are ready

Placement is mapping of user logic to
the cells on the chip
Routing with given nets and
programmable interconnection points
Files for programming

Files for Synthesis

Design Compiler
Setup File

VHDL Description

Design Constraints

Design Compiler
Script

Synchronous Constraint Example

(From Xilinx: "Advanced Software Design with Xilinx M1-Based Software")

OFFSET defines the delay of a signal external to the chip, relative to a clock. Internal clock delays are determined by Software

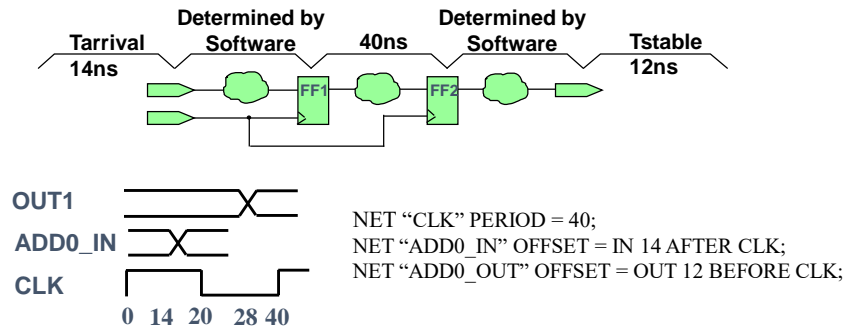

18/03/2019

Universität Rostock, IEF, Institut GS

133

Practical Exercise: Controlling a VGA-Monitor

Task:

One part of a VGA-circuit is the creation of signals for synchronization of the monitor and the DAC (digital to analog converter). Depending of the resolution and the picture rate of the monitor it has to create a distinct pattern for the signals:

HSYNC - horizontal synchronization signal (row)

VSYNC - vertical synchronization signal (picture) und

BLANK - blanking of the beam (horizontal and vertical), signal to the DAC

This part of a VGA controller will be designed and tested in this exercise.

All signals are derived from the pixel clock fp:

$fp = \text{picture rate} * \text{number of rows} * \text{number of pixels per row}$

18/03/2019

Universität Rostock, IEF, Institut GS

134

Practical Training: Controlling a VGA-Monitor

The numbers of rows and pixels per row include the time (expressed in numbers of rows/pixels) for blanking outside the border of the visible picture and for the horizontal and vertical retrace of the beam.

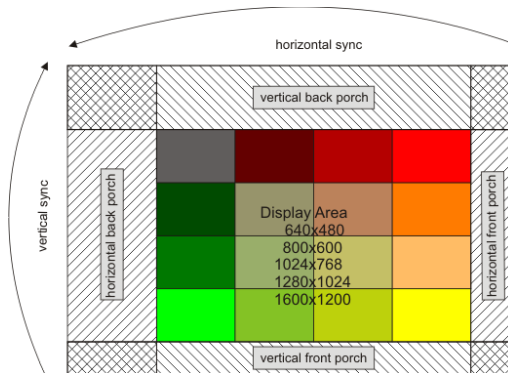

18/03/2019

Universität Rostock, IEF, Institut GS

135

Resolution Refresh	Clock M/D for DCM	H-Active	H-Front-Porch	H-SYNC	H-Back-Porch	V-Active	V-Front-Porch	V-SYNC	V-Back-Porch
640x480 @60Hz	25.175 2/8	640	16	96 (low)	48	480	10	2 (low)	33
640x480 @75Hz	31.5 5/16	640	16	64 (low)	120	480	1	3 (low)	16
800x600 @72Hz	50 2/4	800	56	120 (high)	64	600	37	6 (high)	23
1024x768 @60Hz	65 13/20	1024	24	136 (low)	80	768	3	6 (low)	29
1024x768 @75Hz	78.75 11/14	1024	16	96 (high)	176	768	1	3 (high)	28
1280x1024 @60Hz	108 27/25	1280	48	112 (low)	248	1024	1	3 (low)	38

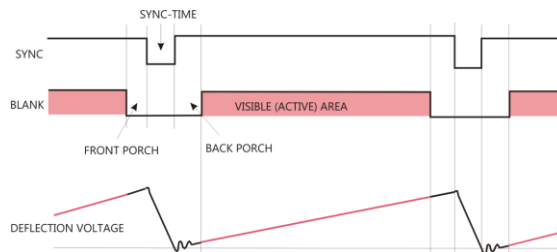

18/03/2019

Universität Rostock, IEF, Institut GS

136

VGA-part of demonstration board with XCS3S2000-FG676:

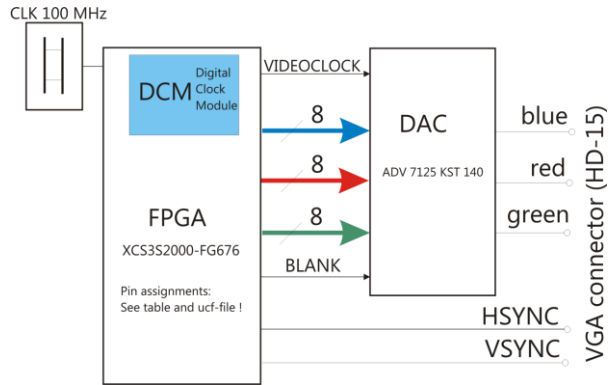

VGA-part of demonstration board with XCS3S2000-FG676:

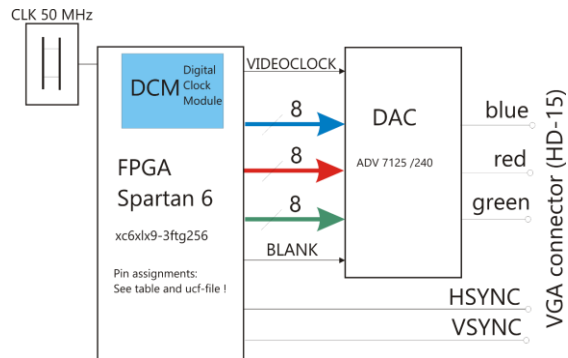

Displaying objects on display 1

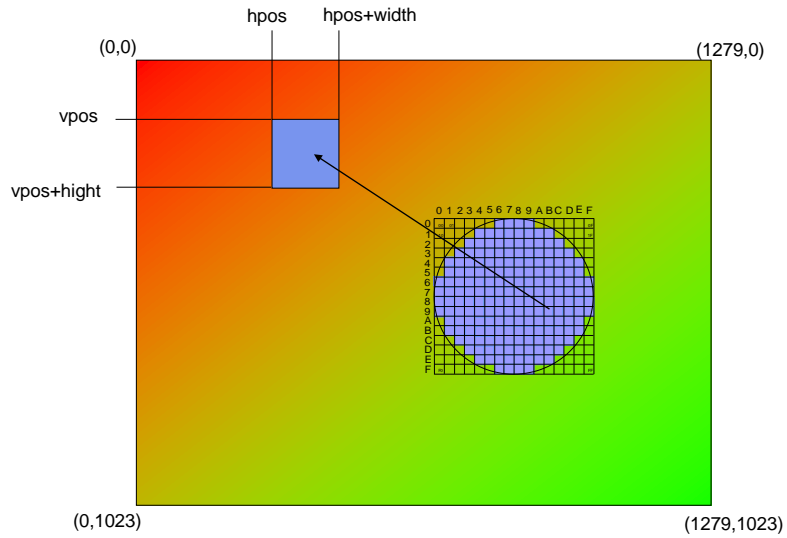

Displaying objects on display 1

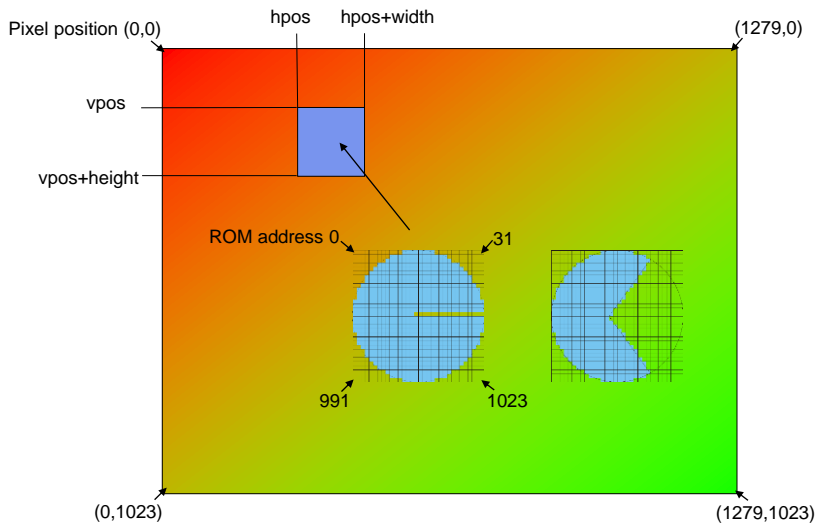

Displaying objects on display 2

Object:

If $hpos \leq horizontal_counter < (hpos + width)$ and $vpos \leq vertical_counter < (vpos + height)$ then replace background color by foreground.

Object with pattern:

If $hpos \leq horizontal_counter < (hpos + width)$ and $vpos \leq vertical_counter < (vpos + height)$ then look into the memory and increase the memory address by 1.

If memory content is a '1' then replace background color by foreground.

Memory address is set to 0 when a new picture starts.

Memory size is $width \cdot height$. Memory width is 1 bit.

Moving object with pattern:

Change $hpos$ and/or $vpos$ values with every new picture displayed.

Object with variable pattern:

Use memory with n bit width. Use every bit in the word for another pattern and display depending upon actual position.

18/03/2019

Universität Rostock, IEF, Institut GS

141

Avoiding (supressing) Hazards

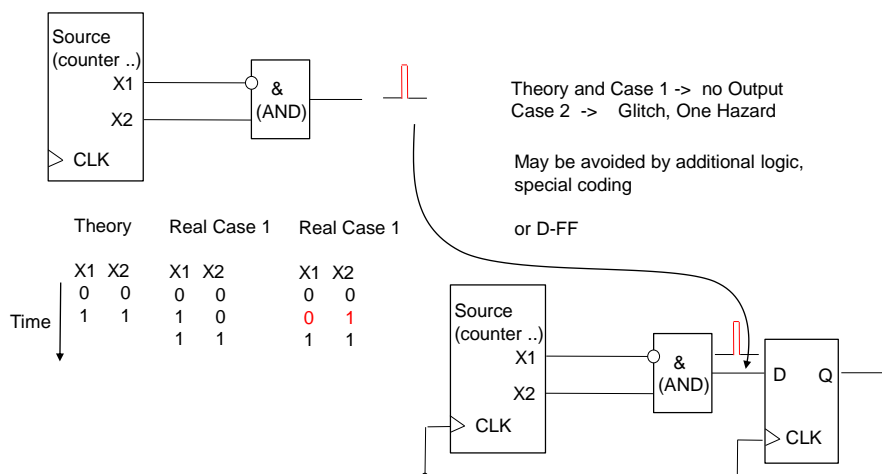

18/03/2019

Universität Rostock, IEF, Institut GS

142

Synchronous Output Changes (and avoid hazards at outputs)

Source (counter ...)

X1

X2

& (AND)

D Q

OUTPUT_SIGNAL

CLK

Use a FF in the Output Cell here!

Process Properties - Map Properties

Property Name	Value
Ignore User Timing Constraints	<input type="checkbox"/>
Timing Mode	Non Timing Driven
Trim Unconnected Signals	<input checked="" type="checkbox"/>
Generate Detailed MAP Report	<input checked="" type="checkbox"/>
Pack I/O Registers/Latches into IOBs	For Inputs and Outputs
Power Reduction	
Power Activity File	

Design Goals and Strategies must not be locked anywhere

18/03/2019

Universität Rostock, IEF, Institut GS

143

Synchronous Output Changes (and avoid hazards at outputs) Example VGA control

Avoid direct output from logic functions (gates)
Use Flip-Flops in the IOBs of the FPGA as last memory

```
hsync_int <= some assignment; -- decoding counter values
red_int <= another assignment; -- maybe multiplexer background, black, pacman
.....
```

```
assign_outputs : process(hclk)
  if rising_edge(hclk) then
    HSYNC <= hsync_int;
    VSYNC <= vsync_int;
    BLANK <= blank_int;
    RED <= red_int;
    GREEN <= green_int;
    BLUE <= blue_int;
  end if;
end process assign_outputs;
```

Possible to have expressions here:
BLANK <= hblank and vblank;

Phase relationship hclk to VIDEOCLK ? Expected: VIDEOCLK delayed like the other outputs

18/03/2019

Universität Rostock, IEF, Institut GS

144

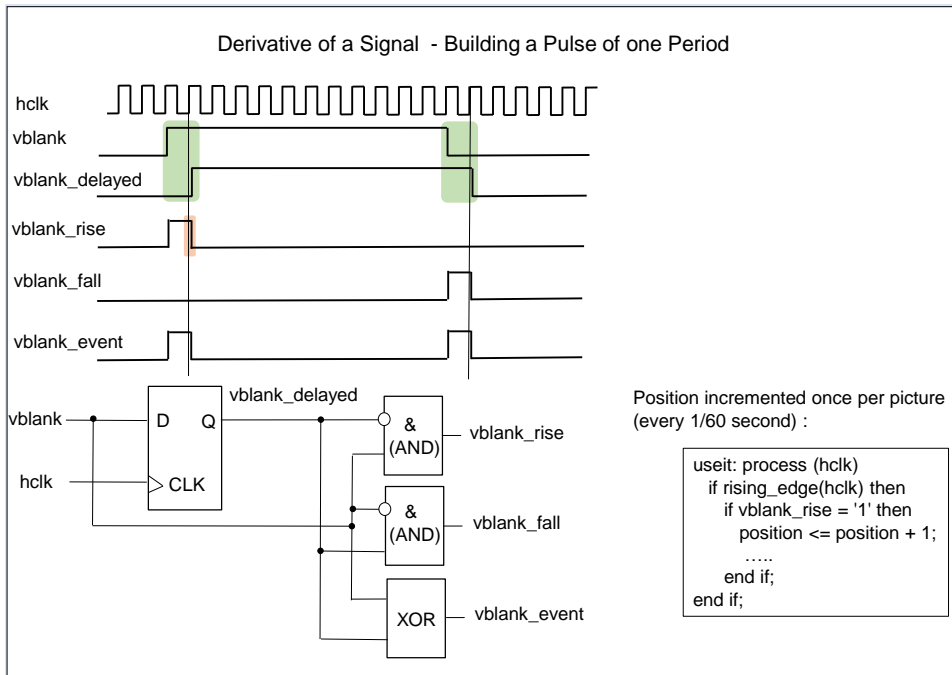

18/03/2019

Universität Rostock, IEF, Institut GS

145

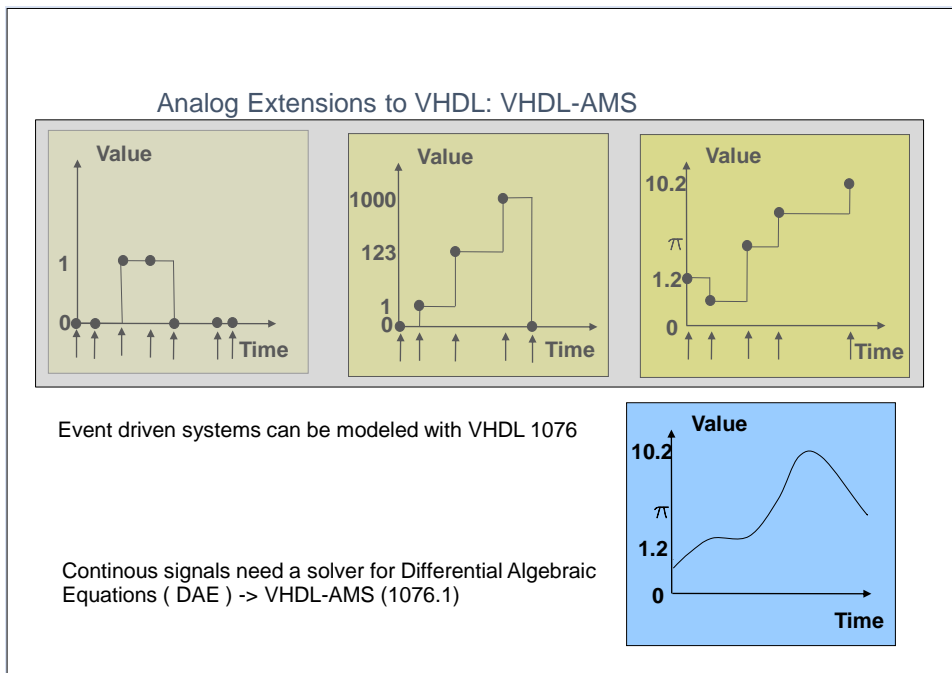

18/03/2019

Universität Rostock, IEF, Institut GS

146

Energy Domains, Terminals, Natures

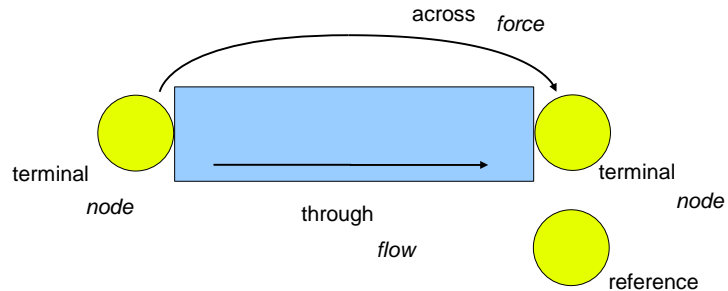

subtype voltage is real tolerance "default_voltage";
...

nature electrical is
voltage **across**
current **through**
electrical_ref **reference**;

nature thermal is
temperature **across**
heat_flow **through**
thermal_ref **reference**;

18/03/2019

Universität Rostock, IEF, Institut GS

147

Standard Natures

External packages, not included in VHDL (like std_logic);

```
library ieee_proposed;
use ieee_proposed.electrical_systems.all;
```

Proposed standard packages for modelling of various energy domains

nature	across type, through type	package
electrical	voltage, current	electrical_systems
magnetic	mmf (ampere turns), flux (weber)	
translational_v	velocity, force (dynamic systems)	mechanical_systems
rotational_v	displacement, force (static systems)	
rotational	velocity, torque (Nm)	
fluidic	angle, torque	
thermal	pressure, volumeflow rate (m ³ /s)	fluidic_systems
radiant	temperature, heat flow rate (joule/s)	thermal_systems
	illuminance (candela), optic flux (lumen)	radiant_systems

18/03/2019

Universität Rostock, IEF, Institut GS

148

Quantity

New object : Quantity -> Unknown of differential algebraic equations

$$F(x, dx/dt, t)$$

Free Quantities: Signal flow modeling
Branch Quantities: Modeling conservative energy systems
 Source Quantities: Modeling sources and noise

Example: Capacitor with leakage
 (one across, two through branches)

Terminal p1,p2: **electrical**;

Quantity vc across ic,ileak through p1 to p2;

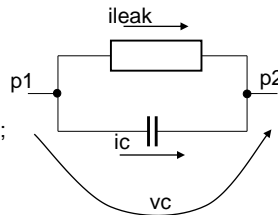

18/03/2019

Universität Rostock, IEF, Institut GS

149

Attributes of Quantities

Q`tolerance	Tolerance group of the quantity String – "accurate_voltage", "default_voltage"
Q'dot	Derivative of Q with respect to time (dQ/dt)
Q'integ	Integral of Q with respect to time
Q'above/expr)	Boolean signal, true if Q>expr, else false
Q'delayed(T)	Used to generate events for digital simulation New quantity with the value of Q delayed by T
Q'slew(max_rising,max_falling)	Quantity that follows Q but the edges/slopes are limited by the values of max_rising, max_fallin

$\int Q dt$

Q'ltf (num, den) Laplace-domain transfer function of Q, where num and den are the numerator and denominator coefficients of the transforming system as real vectors

Q'zoh(t_sample, t_initial) Sampled version of Q with a sample rate of t_sample and first sample at t_initial (omitted if first sample at 0.0)

Q'ztf(num, den, t_sample, t_initial) Z-transfer domain function of Q, where num and den are the numerator and denominator of the transform as real vectors

18/03/2019

Universität Rostock, IEF, Institut GS

150

Attributes of Signals that are Quantities

Attributes of Signals that are only available for AMS
Interface between digital and analog world

$S'_{\text{ramp}}(t_{\text{rise}}, t_{\text{fall}})$	Quantity following S with the given rise and fall times (no discontinuity) S must be of a real type
$S'_{\text{slew}}(\text{rising_slope}, \text{falling_slope})$	Quantity following S with given (not max.) rising and falling slopes