

**VHDL-Lab 1: Counter 0000 ... 9999**

**Problem:**

Design a counter, counting from 00 to 99 (expandable to 0000 to 9999) so that each of the two (4) digits is counted separately in a nibble (4 bit) from 0 to 9. Decode the result for 7 segment LED displays. The displays use common 7 segment inputs (low active) and have a common anode. The common anode is switched to supply voltage by signals AN0 (Lowest) to AN3 (Highest). The ANx-signals are low active too. Only one display shall be active at once (multiplex).

The display duration per digit shall be 1 ms.

See: [http://www.digilentinc.com/Data/Products/BASYS2/Basys2\\_rm.pdf](http://www.digilentinc.com/Data/Products/BASYS2/Basys2_rm.pdf)

**xc3s100e-5cp132**

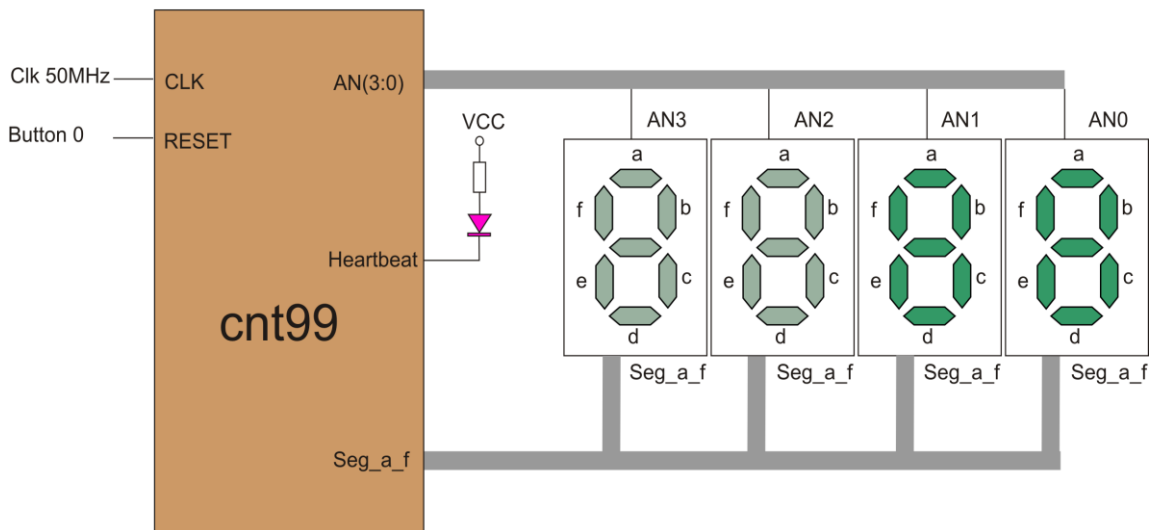

1. Prepare a VHDL-Description for the design and a testbench. Proposed identifiers: cnt99.vhd, cnt99\_tb.vhd.
2. Simulate the VHDL design using Modelsim-Simulator.
3. Synthesize the design into a Xilinx xc3s100e-5cp132-device using the pin assignments from the following table:

Signal	Pin
a	L14 (active low -> Display on when low, off when high)
b	H12 (active low -> Display on when low, off when high)
c	N14 (active low -> Display on when low, off when high)
d	N11 (active low -> Display on when low, off when high)
e	P12 (active low -> Display on when low, off when high)
f	L13 (active low -> Display on when low, off when high)
g	M12 (active low -> Display on when low, off when high)
Clock (50 MHz)	B8
Reset (Button 0)	G12 (active low -> reset to 00 when low)

Heartbeat	M5
AN0	F12 (active low -> Display on when low, off when high)
AN1	J12 (active low -> Display on when low, off when high)
AN2	M13 (active low -> Display on when low, off when high)
AN3	K14 (active low -> Display on when low, off when high)

4. Use ISE-synthesis (XSI) to implement the design.  
How many cells are used for the design?
5. Simulate the placed and routed design (timing simulation) using Modelsim again. What is the maximum speed of your design?
6. Test your design. Download the bit file to the Digilent BASYS 2 testboard.
7. Introduce generics to accelerate simulation.
8. Add a "Heartbeat"-output blinking with 1 Hz.
9. Use a separate package file for declaration of types and for declaration and implementation of subroutines.
10. Write counter values to a file during simulation.